

Technical Description

The Model VCMS-PM1 Power Module is a component of the InPower Vehicle Control Module System (VCMS), a modular, programmable switch panel system used for controlling vehicle 12 volt auxiliary devices. The system can be configured to fit a wide range of applications that require the driver to operate devices such as lights, beacons, fans, compressors, pumps, etc. The power module provides power outputs and digital inputs to control these devices, and links to the switch module and other power modules via an interconnecting logic cable. A system configuration can contain up to five power modules. It is also possible to use dual switch modules in a master/slave arrangement to provide system control from two locations.

Key Features

- **Small Size and Low Profile**
- **Six 12 Volt 15 Amp Power Outputs**
- **Four Digital Inputs**
- **Modular/Expandable Design**
- **Remote Operation**
- **Programmable Control Logic Functions**

The power module contains six 12 volt DC power outputs rated at 15 amps each that include over current and short circuit automatic fault shutdown protection. Four digital inputs are provided for monitoring external conditions such as ignition switch on, transmission in Park, etc. These inputs can be individually programmed to activate from either a contact closure to ground or to +12 volts. All wire connections utilize ¼ inch male faston blade terminals.

The VCMS-PM1 power module contains a communications interface with a ribbon connector. This interface allows the module to communicate with other power modules and switch modules. As a VCMS configuration may contain more than one power module, each module contain a communication address (Mod 1, Mod2, etc.).

Ordering Guide

Model	Description
VCMS-PM1	Power Module

System Diagram

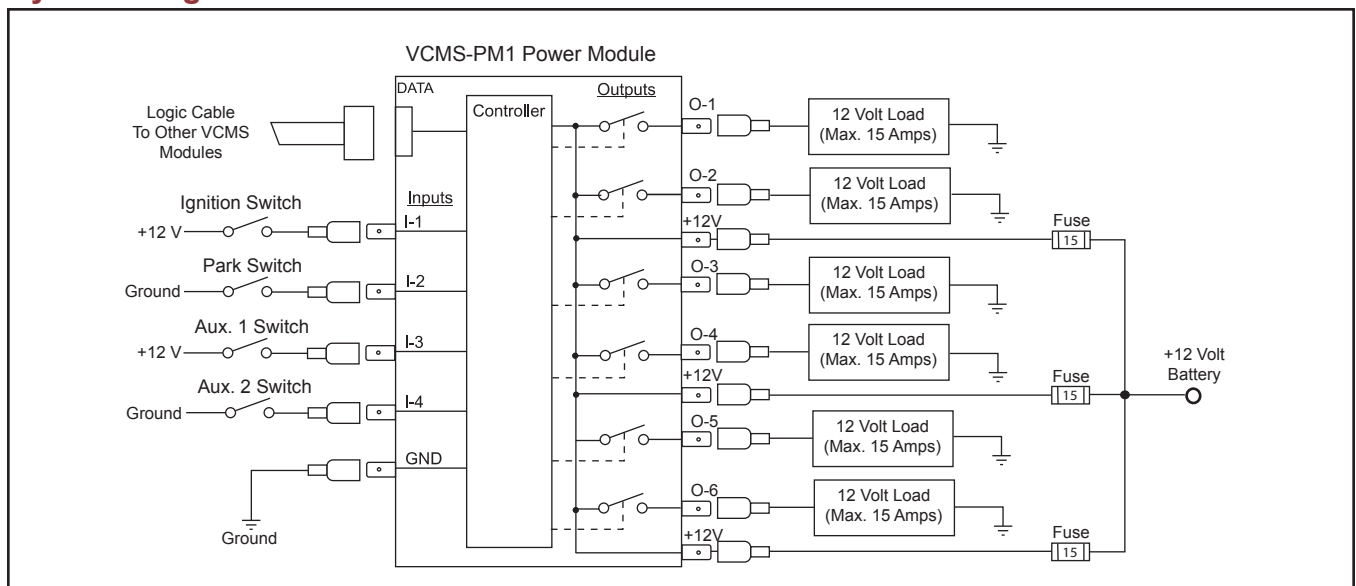

VCMS-PM1 Power Module

Specifications

Dimensions:	2.25 inch W x 4.15 inch L x 0.53 inch H
Case Material:	Anodized aluminum
Mounting:	Mount on flat metal panel with four #6-32 screws
Connector:	10-position, for ribbon cable plug
Outputs:	Six high-side drivers rated at +12 volts @ 15 amps
Inputs:	Four, programmable to pull up for ground true actuation or to pull down for +12 volt true actuation
Module Address:	Power modules are preprogrammed with a module number address (Mod 1, Mod 2, etc.)

Reference Documents

<u>Document Name</u>	<u>Document Number</u>
VCMS-PM1 Installation Instructions	Owners Manual OM-107

Mechanical Drawing

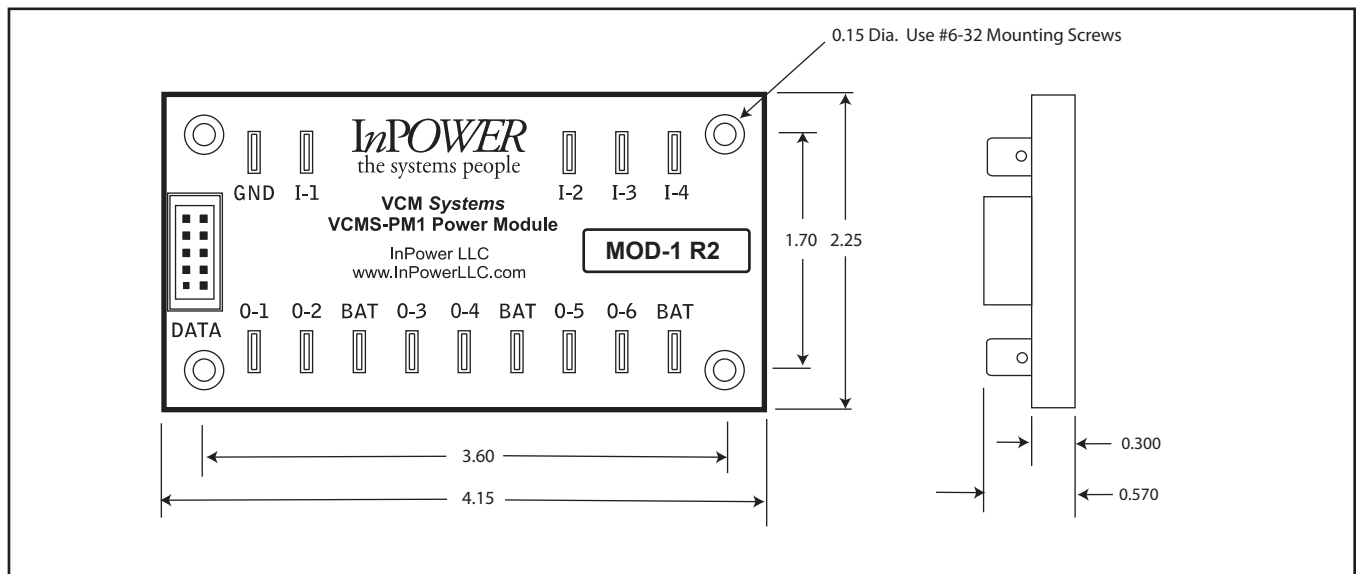

InPower LLC

Offered by:

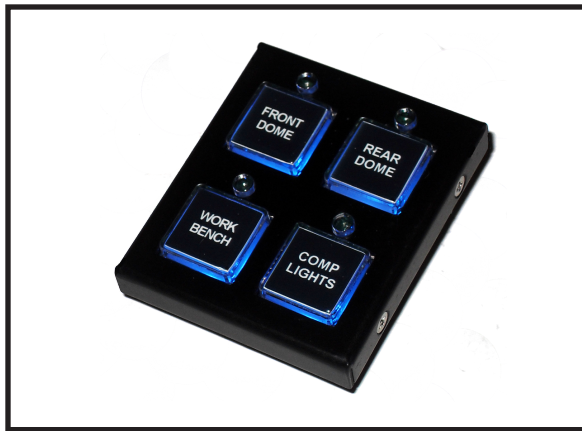

Technical Description

The Model VCMS-SM4 Switch Module is a component of the InPower *Vehicle Control Module System (VCMS)*, a modular, programmable switch panel system used for controlling vehicle 12 volt auxiliary devices. The system can be configured to fit a wide range of applications to operate devices such as lights, beacons, fans, compressors and pumps. The switch module is connected to one or more power modules by a logic cable. Dual switch modules may be used in a master/slave arrangement, offering system control from two locations.

The Model VCMS-SM4 Switch Module contains four push button switches. The push buttons utilize a tactile switch design that ensures a positive operation. Each switch is back lighted for night viewing, and contains a status LED indicator. The housing is a durable metal case that is only ½ inch thick. Switch legends are easily replaceable and are available in standard and custom formats.

Switch modules interface to other system modules by a logic cable that plugs into a connector on the rear of the unit. The switch module mounts to a panel with four 6-32 threaded studs and is intended for interior vehicle locations.

Each switch can be programmed to operate as a momentary, two-position, or three-position latching function. If programmed as a momentary function, the switch output and the status LED will remain activated for the time the switch is depressed. If programmed as a latching function, pressing the switch the first time sets the switch output and status LED. Pressing the switch the second time turns off the switch output and status LED. If the switch is programmed as a 3-step function, pressing the switch the first time sets the output On1. Pressing the switch the second time turns off output On1 and turns on output On2. Pressing the switch the third time turns off output On2. This operation provides the equivalent of a three position switch.

Key Features

- Ultra Thin Profile
- Back Lighted Switches
- Custom and Standard Legends
- Switch Status Indicators
- Programmable Functions
- Easy to Install Cable

Ordering Guide

Model	Description
VCMS-SM4	Four-position VCMS switch module

System Diagram

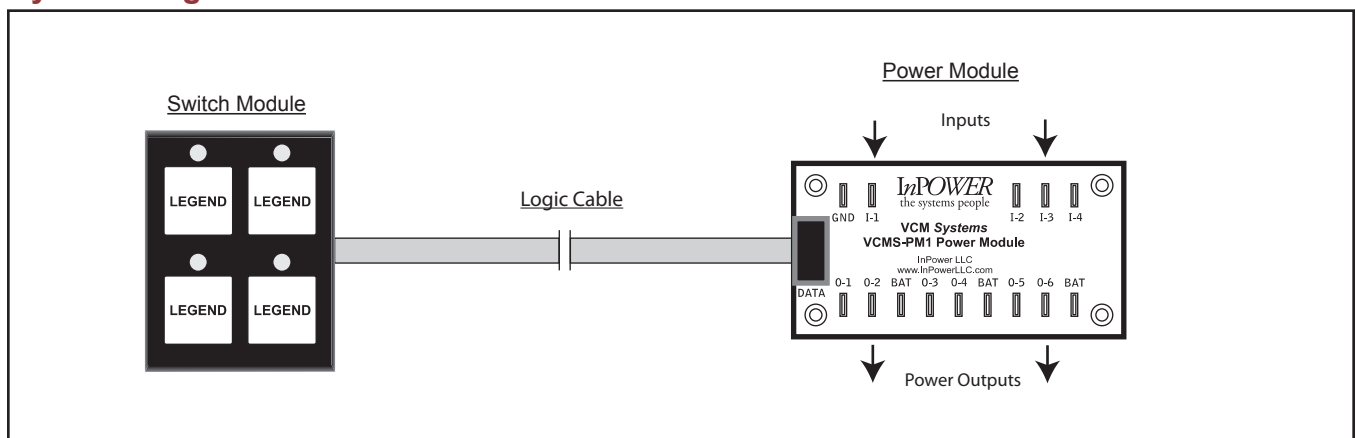

VCMS Four-Position Switch Module

Specifications

Dimensions:	2.74 inch H x 2.33 inch W x 0.55 inch D
Case Material:	Anodized aluminum
Mounting:	Four 0.680 inch #6-32 threaded studs
Connector:	10-position, for ribbon cable plug
Status Indicator:	Red LED
Back Light:	Blue
Switch Cap:	Molded plastic, with legend label and diffuser
Switch Functions:	Programmable via VCMS Application Program: <ol style="list-style-type: none">1. Momentary2. 2-position latching (Off-On1)3. 3-Step (Off-On1-On2)
Switch Legends:	Select from InPower's standard switch legend library, InPower document TB-59. Custom legends are also available.

Reference Documents

Document Name	Document Number
VCMS-SM6 Switch Module, 6 positions	Product Data Sheet PDS-92
VCMS-SM8 Switch Module, 8 positions	Product Data Sheet PDS-93
VCMS-SM10 Switch Module, 10 positions	Product Data Sheet PDS-94
VCMS-SM12 Switch Module, 12 positions	Product Data Sheet PDS-95
VCMS-PM1 Power Module	Product Data Sheet PDS-96
VCMS-PM2 Power Module	Product Data Sheet PDS-101
VCMS-APM Analog Power Module	Product Data Sheet PDS-97
VCMS-SC Technical Manual	Owners Manual OM-96
VCMS Switch Legend Library	Technical Bulletin TB-59

Mechanical Drawing

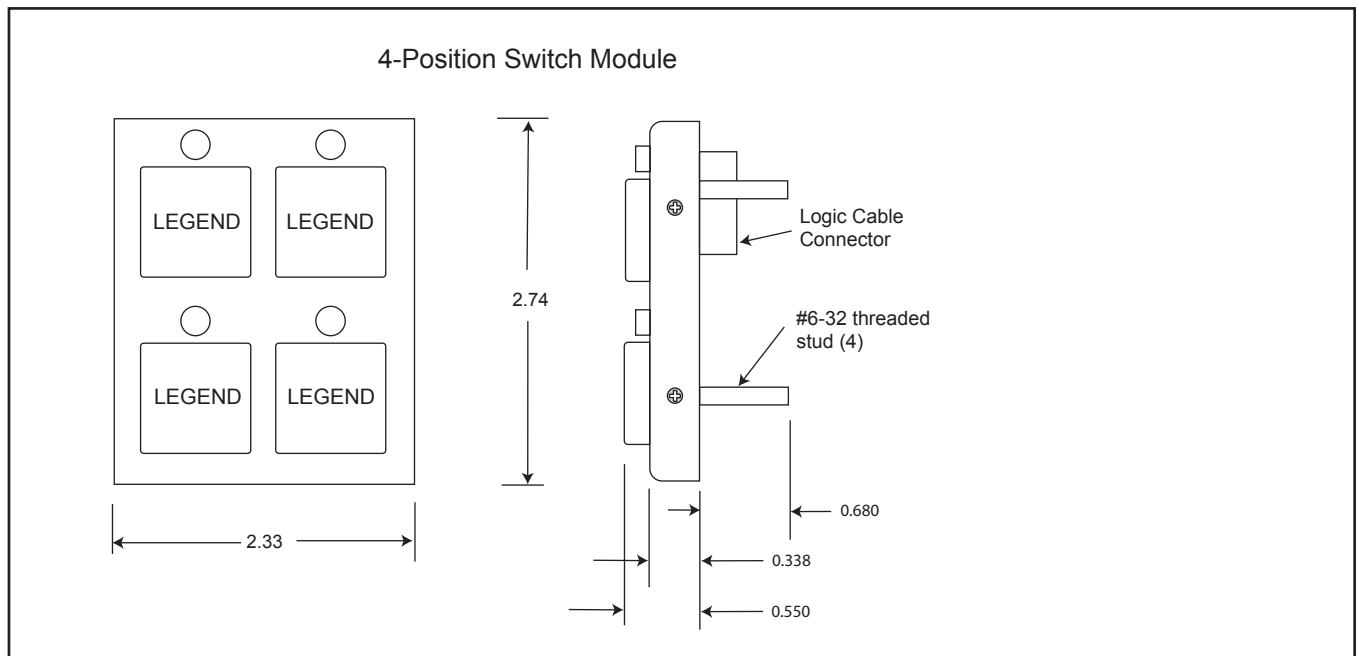

InPower LLC

Offered by:



Key Features

- Ultra Thin Profile
- Back Lighted Switches
- Custom and Standard Legends
- Switch Status Indicators
- Programmable Functions
- Easy to Install Cable

Ordering Guide

Model	Description
VCMS-SM6	Six-position VCMS switch module

Technical Description

The Model VCMS-SM6 Switch Module is a component of the InPower *Vehicle Control Module System (VCMS)*, a modular, programmable switch panel system used for controlling vehicle 12 volt auxiliary devices. The system can be configured to fit a wide range of applications that require the driver to operate devices such as lights, beacons, fans, compressors and pumps. The switch module is connected to one or more power modules via a logic cable. Dual switch modules may be used in a master/slave arrangement, offering system control from two locations.

The Model VCMS-SM6 Switch Module contains six push button switch positions. The push buttons utilize a tactile switch design that ensures a positive operation. Each switch position contains a back lighted push button for night viewing, and a status LED indicator. The housing is a durable metal case that is only ½ inch thick. Switch legends are easily replaceable and are available in standard and custom formats.

Switch modules interface to other system modules via a logic cable that plugs into a connector on the rear of the unit. The switch module mounts to a panel with four 6-32 threaded studs and is intended for interior vehicle locations.

Each switch position can be programmed to be a momentary, two-position latching, or three-position latching function. If programmed as a momentary function the switch output and the status LED will remain activated for the time the switch is activated. If programmed as a latching function, pressing the switch the first time sets the switch output and status LED. Pressing the switch the second time turns off the switch output and status LED. If the switch was programmed as a 3-step function, pressing the switch the first time sets the first switch position output (On1). Pressing the switch the second time turns off the first output and turns on the second output (On2). Pressing the switch the third time turns off the second output. This operation provides the equivalent of a three position switch.

System Diagram

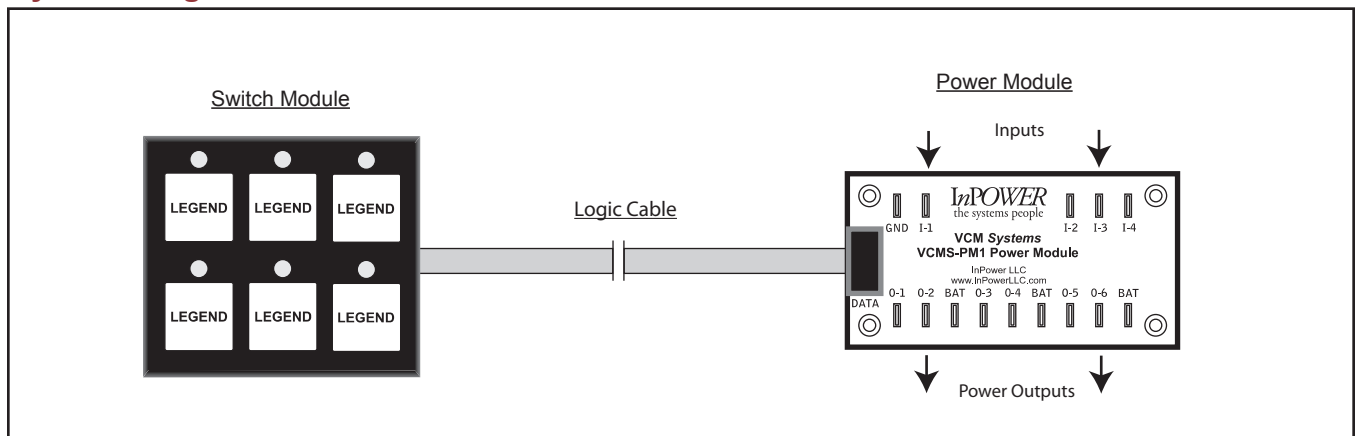

VCMS Six-Position Switch Module

Specifications

Dimensions:	2.74 inch H x 3.33 inch W x 0.55 inch D
Case Material:	Anodized aluminum
Mounting:	Four 0.680 inch #6-32 threaded studs
Connector:	10-position, for ribbon cable plug
Status Indicator:	Red LED
Back Light:	Blue
Switch Cap:	Molded plastic, with legend label and diffusor
Switch Functions:	Programmable via VCMS Application Program: <ol style="list-style-type: none">1. Momentary2. 2-position latching (Off-On1)3. 3-Step (Off-On1-On2)
Switch Legends:	Select from InPower's standard switch legend library, InPower document TB-59. Custom legends are also available.

Reference Documents

Document Name	Document Number
VCMS-SM8 Switch Module, 8 positions	Product Data Sheet PDS-93
VCMS-SM10 Switch Module, 10 positions	Product Data Sheet PDS-94
VCMS-SM12 Switch Module, 12 positions	Product Data Sheet PDS-95
VCMS-PM1 Power Module	Product Data Sheet PDS-96
VCMS-PM2 Power Module	Product Data Sheet PDS-101
VCMS-APM Analog Power Module	Product Data Sheet PDS-97
VCMS Design Manual	Owners Manual OM-96
VCMS Switch Legend Library	Technical Bulletin TB-59

Mechanical Drawing

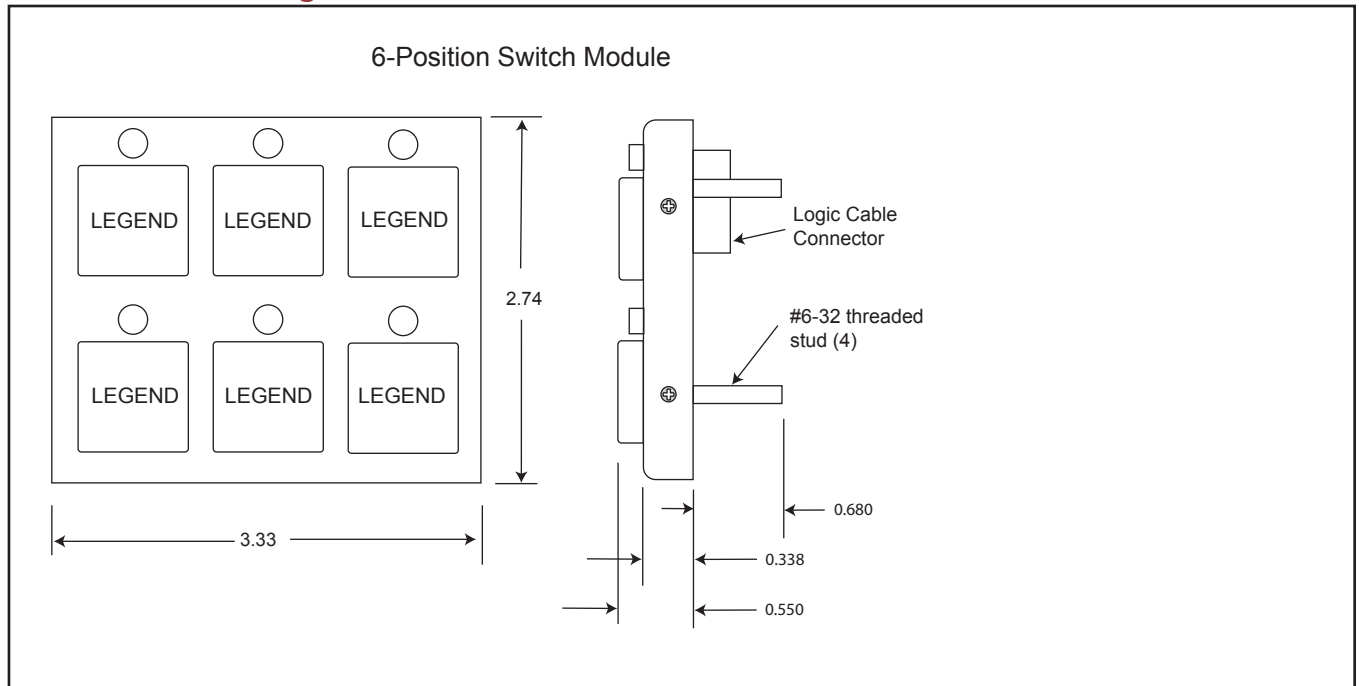

InPower LLC

Offered by:

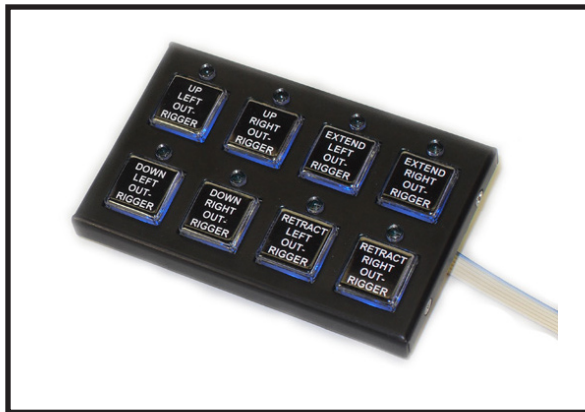

Technical Description

The Model VCMS-SM8 Switch Module is a component of the InPower *Vehicle Control Module System (VCMS)*, a modular, programmable switch panel system used for controlling vehicle 12 volt auxiliary devices. The system can be configured to fit a wide range of applications that require the driver to operate devices such as lights, beacons, fans, compressors and pumps. The switch module is connected to one or more power modules via a logic cable. Dual switch modules may be used in a master/slave arrangement, offering system control from two locations.

The Model VCMS-SM8 Switch Module contains eight push button switch positions. The push buttons utilize a tactile switch design that ensures a positive operation. Each switch position contains a back lighted push button for night viewing, and a status LED indicator. The housing is a durable metal case that is only 1/2 inch thick. Switch legends are easily replacable and are available in standard and custom formats.

Switch modules interface to other system modules via a logic cable that plugs into a connector on the rear of the unit. The switch module mounts to a panel with four 6-32 threaded studs intended for interior vehicle locations.

Each switch position can be programmed to be a momentary, two-position latching, or three-position latching function. If programmed as a momentary function the switch output and the status LED will remain activated for the time the switch is activated. If programmed as a latching function, pressing the switch the first time sets the switch output and status LED. Pressing the switch the second time turns off the switch output and status LED. If the switch was programmed as a 3-step function, pressing the switch the first time sets the first switch position output (On1). Pressing the switch the second time turns off the first output and turns on the second output (On2). Pressing the switch the third time turns off the second output. This operation provides the equivalent of a three position switch.

Key Features

- Ultra Thin Profile
- Back Lighted Switches
- Custom and Standard Legends
- Switch Status Indicators
- Programmable Functions
- Easy to Install Cable

Ordering Guide

Model	Description
VCMS-SM8	Eight-position VCMS switch module

System Diagram

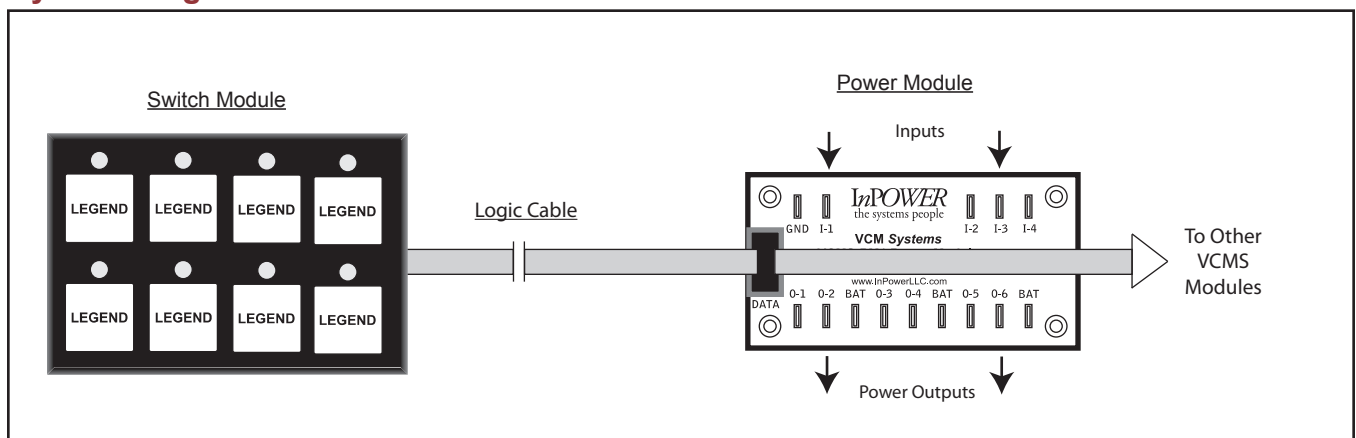

VCMS Eight-Position Switch Module

Specifications

Dimensions:	2.74 inch H x 4.33 inch W x 0.55 inch D
Case Material:	Anodized aluminum
Mounting:	Four 0.680 inch #6-32 threaded studs
Connector:	10-position, for ribbon cable plug
Status Indicator:	Red LED
Back Light:	Blue
Switch Cap:	Molded plastic, with legend label and diffusor
Switch Functions:	Programmable via VCMS Application Program: 1. Momentary 2. 2-position latching (Off-On1) 3. 3-Step (Off-On1-On2)
Switch Legends:	Select from InPower's standard switch legend library, InPower document TB-59. Custom legends are also available.

Reference Documents

Document Name	Document Number
VCMS-SM6 Switch Module, 6 positions	Product Data Sheet PDS-92
VCMS-SM10 Switch Module, 10 positions	Product Data Sheet PDS-94
VCMS-SM12 Switch Module, 12 positions	Product Data Sheet PDS-95
VCMS-PM1 Power Module	Product Data Sheet PDS-96
VCMS-PM2 Power Module	Product Data Sheet PDS-101
VCMS-APM Analog Power Module	Product Data Sheet PDS-97
VCMS-SC Technical Manual Owners Manual OM-96	

Mechanical Drawing

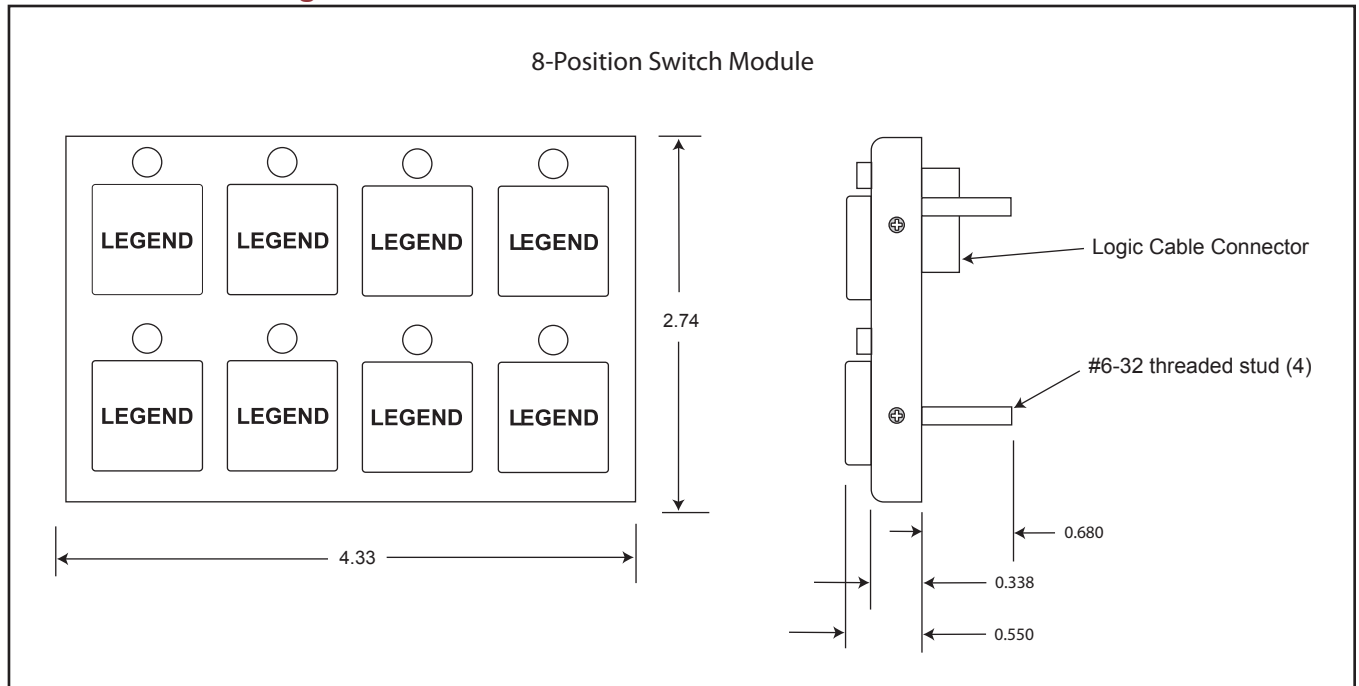

InPower LLC

Offered by:



Key Features

- Ultra Thin Profile
- Back Lighted Switches
- Custom and Standard Legends
- Switch Status Indicators
- Programmable Functions
- Easy to Install Cable

Ordering Guide

Model	Description
VCMS-SM10	Ten-position VCMS switch module

System Diagram

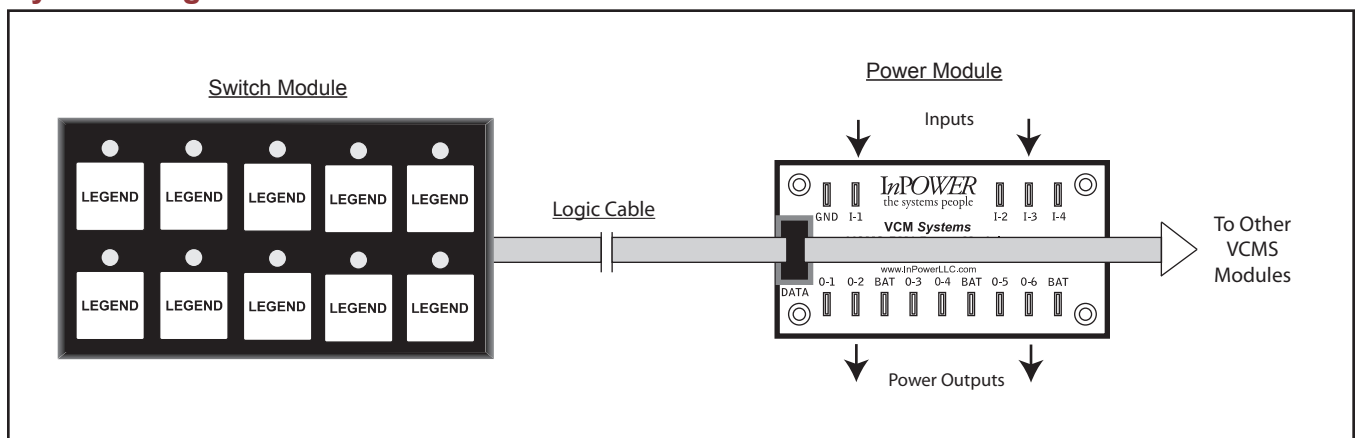

Technical Description

The Model VCMS-SM10 Switch Module is a component of the InPower *Vehicle Control Module System (VCMS)*, a modular, programmable switch panel system used for controlling vehicle 12 volt auxiliary devices. The system can be configured to fit a wide range of applications that require the driver to operate devices such as lights, beacons, fans, compressors and pumps. The switch module is connected to one or more power modules via a logic cable. Dual switch modules may be used in a master/slave arrangement, offering system control from two locations.

The Model VCMS-SM10 Switch Module contains ten push button switch positions. The push buttons utilize a tactile switch design that ensures a positive operation. Each switch position contains a back lighted push button for night viewing, and a status LED indicator. The housing is a durable metal case that is only ½ inch thick. Switch legends are easily replaceable and are available in standard and custom formats.

Switch modules interface to other system modules via a logic cable that plugs into a connector on the rear of the unit. The switch module mounts to a panel with four 6-32 threaded studs and is intended for interior vehicle locations.

Each switch position can be programmed to be a momentary, two-position latching, or three-position latching function. If programmed as a momentary function the switch output and the status LED will remain activated for the time the switch is activated. If programmed as a latching function, pressing the switch the first time sets the switch output and status LED. Pressing the switch the second time turns off the switch output and status LED. If the switch was programmed as a 3-step function, pressing the switch the first time sets the first switch position output (On1). Pressing the switch the second time turns off the first output and turns on the second output (On2). Pressing the switch the third time turns off the second output. This operation provides the equivalent of a three position switch.

VCMS Ten-Position Switch Module

Specifications

Dimensions:	2.74 inch H x 5.33 inch W x 0.55 inch D
Case Material:	Anodized aluminum
Mounting:	Four 0.680 inch #6-32 threaded studs
Connector:	10-position, for ribbon cable plug
Status Indicator:	Red LED
Back Light:	Blue
Switch Cap:	Molded plastic, with legend label and diffusor
Switch Functions:	Programmable via VCMS Application Program: 1. Momentary 2. 2-position latching (Off-On1) 3. 3-Step (Off-On1-On2)
Switch Legends:	Select from InPower's standard switch legend library, InPower document TB-59. Custom legends are also available.

Reference Documents

Document Name	Document Number
VCMS-SM6 Switch Module, 6 positions	Product Data Sheet PDS-92
VCMS-SM10 Switch Module, 10 positions	Product Data Sheet PDS-94
VCMS-SM12 Switch Module, 12 positions	Product Data Sheet PDS-95
VCMS-PM1 Power Module	Product Data Sheet PDS-96
VCMS-PM2 Power Module	Product Data Sheet PDS-101
VCMS-APM Analog Power Module	Product Data Sheet PDS-97
VCMS-SC Technical Manual	Owners Manual OM-96
VCMS Switch Legend Library	Technical Bulletin TB-59

Mechanical Drawing

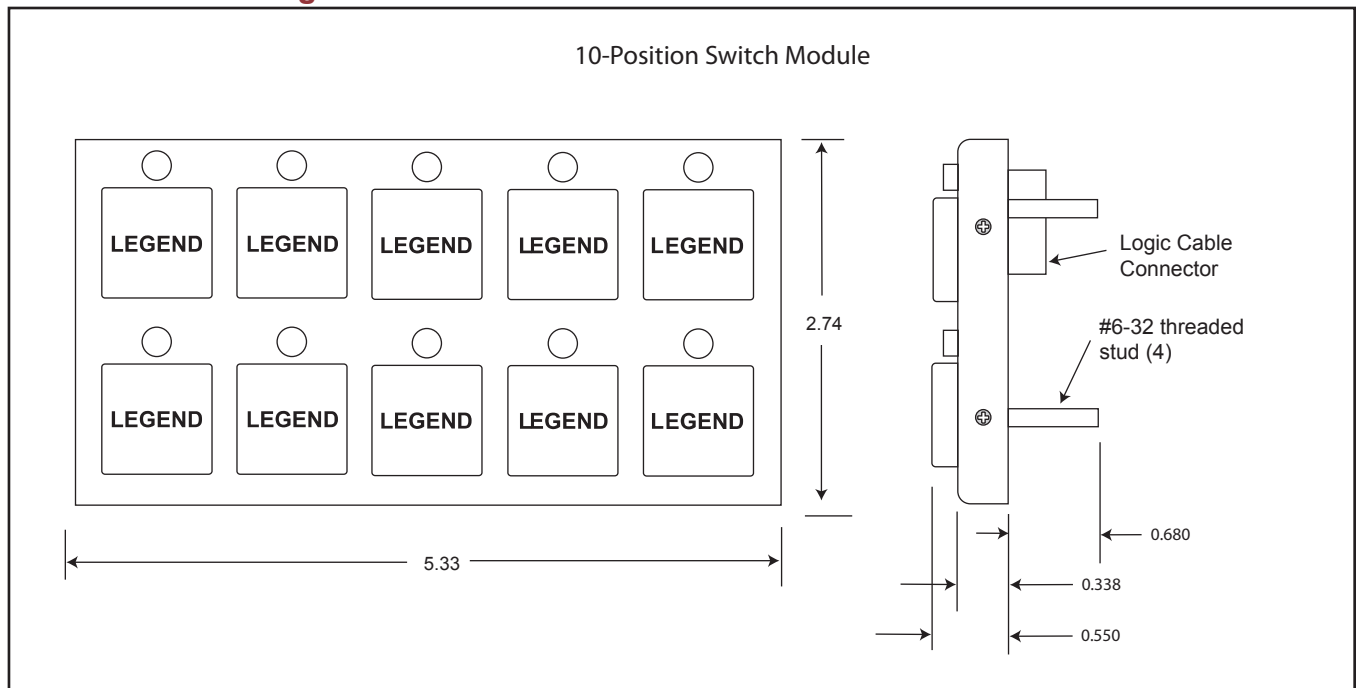

InPower LLC

Offered by:

VCMS2-GM1 VCMS2-GM1-CTRL1

8 Input/ 8 Ground Output Module With Molex Connectors

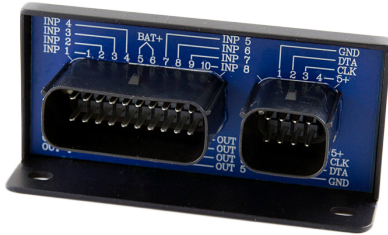

Technical Description

The Model VCMS2-GM1 Ground Output Module is a component of the InPower's second generation Vehicle Control Module System (VCMS2), a modular, programmable switch panel system used for controlling 12 volt auxiliary devices on vehicles. The system can be configured for a wide range of applications controlling devices such as lights, relays, vehicle interfaces, and other devices needing a maximum 1.0 Amps sink. All power modules and switch panels connect via an 8 pin Molex-150 sealed connector and may be daisy-chained to accommodate extra modules and panels.

The power module has eight inputs and eight outputs, connected through a 20 pin Molex-150 sealed connector. The outputs are rated at 1.0 amps sinking each from a 12 V Source. The digital inputs monitor external conditions, such as what gear the transmission is in or if the ignition switch is on, and can be programmed to respond to either ground or +12 V.

Key Features

- Small Size, L-bracket mounting
- Eight Ground Out 1.0 Amp Sinking Outputs
- Eight Digital Inputs
- Modular/Expandable Design
- Remote Operation
- Programmable Control Logic Functions

The GM1 is used in conjunction with VCMS2 Switch Module(s) and Power Modules in different configurations of MOD1 through MOD6 where up to 6 Ground Out or PM1 Power Modules are needed in a system. In these cases the application program is in the main Switch Module.

The GM1-CTRL1 is used in VCMS2 systems that have no switch module(s) (Standalone system). This may be a single GM1-CTRL1 by itself, or with up to 5 other networked GM1s or PM1s (GM1-MOD2 through GM1-MOD6). In this case the application program is located in this VCMS2-GM1-CTRL1.

Related Products

- VCMS2-SM-4 thru SM-12 Switch Modules
- VCMS2-PM1 and CNTRL-1 Power Out Modules

Modules may be ordered as VCMS2-GM1-MOD1, VCMS2-GM1-MOD2, VCMS2-GM1-MOD3, through MOD6 or as a VCMS2-GM1-CTRL1.

Mechanical Drawing

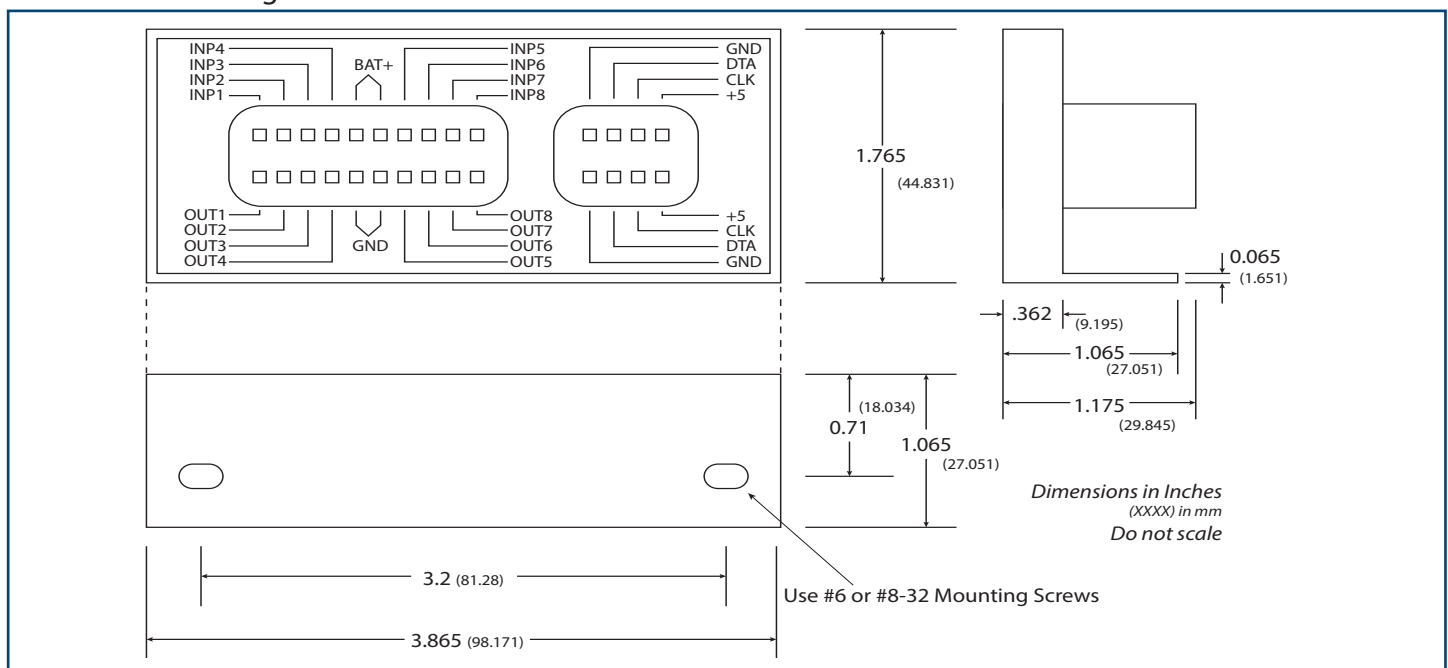

VCMS2-GM1

VCMS2-GM1-CTRL1

8 Input/ 8 Ground Output Module With Molex Connectors

Specifications

Dimensions:	Mounting Surface: 1.065 inches by 3.865 inches. 1.765 inches tall.
Case Material:	Anodized aluminum
Mounting:	Two #6-32 or #8-32 Mounting Screws through L bracket to a flat surface.
Mating Connectors:	One 20 pin A key Molex-150 (part # 33472-2001): inputs, outputs and power One 8 pin A key Molex 150 (part # 33472-0806): ground and data between modules
Outputs:	Eight Low-side drivers rated for Ground Outputs at 1.0 Amps Sink
Inputs:	Eight programmable to pull up for ground true actuation or to pull down for +12 volt true actuation
Orderable Configurations:	VCMS2-GM1-CTRL1 (for Standalone systems (application)), VCMS2-GM1-MOD1, VCMS2-GM1-MOD2, VCMS2-GM1-MOD3, VCMS2-GM1-MOD4, VCMS2-GM1-MOD5, or VCMS2-GM1-MOD6.

Related Products: VCMS2-SM4, VCMS2-SM6, VCMS2-SM8, VCMS2-SM10, VCMS2-SM12 switch modules, and VCMS2-PM1-CTRL1, VCMS2-PM1-MOD1, VCMS2-PM1-MOD2, VCMS2-PM1-MOD3, VCMS2-PM1-MOD4, VCMS2-PM1-MOD5, and VCMS2-PM1-MOD6.

System Diagram

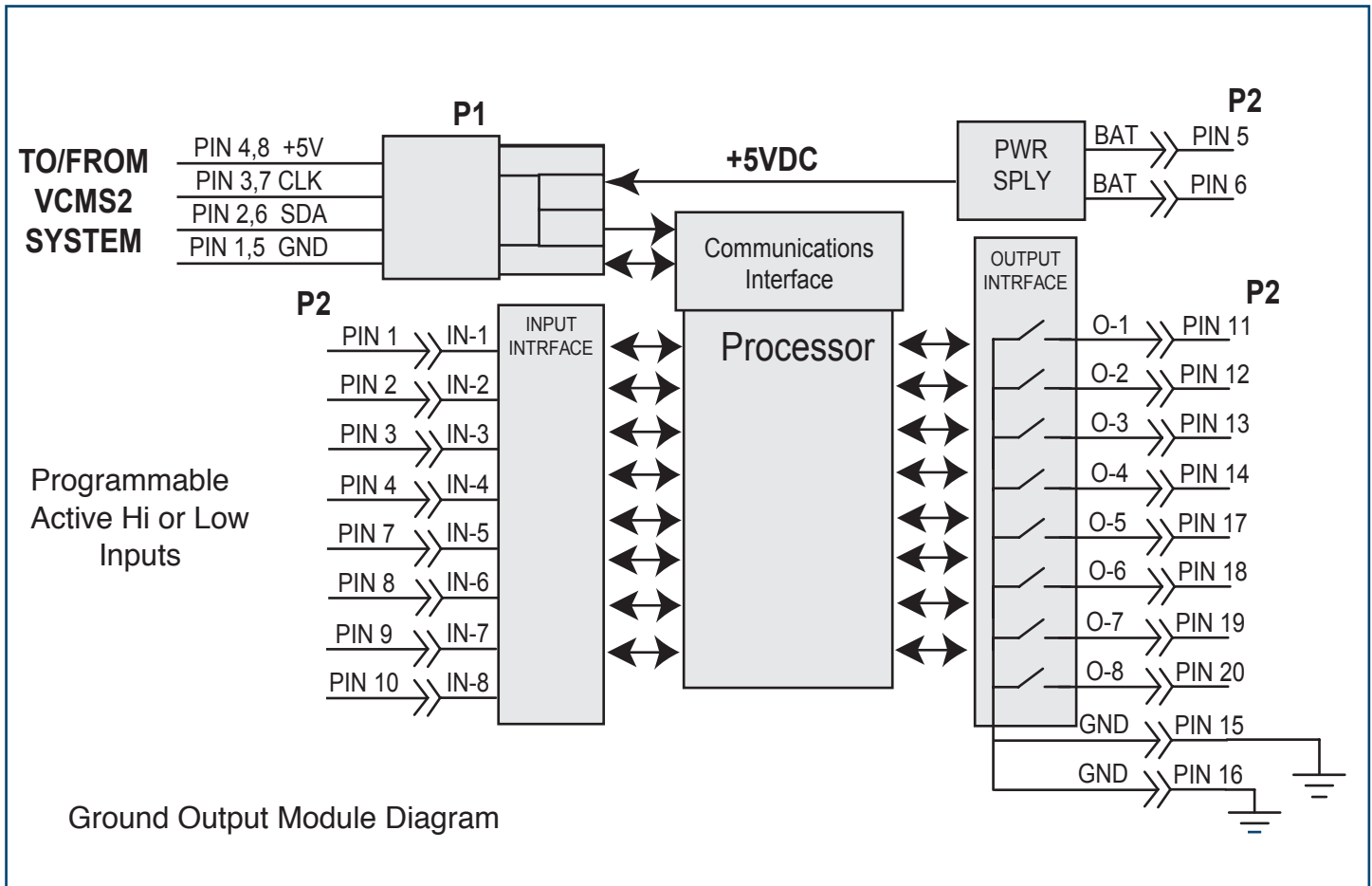

VCMS2-PM1 VCMS2-PM1-CTRL1

8 Input/ 8 Output Power Module
With Molex Connectors



Technical Description

The Model VCMS2-PM1 Power Module is a component of the InPower's second generation Vehicle Control Module System (VCMS2), a modular, programmable switch panel system used for controlling 12 volt auxiliary devices on vehicles. The system can be configured for a wide range of applications controlling devices such as lights, beacons, fans, compressors, and other 12 V devices.

All power modules and switch panels connect via an 8 pin Molex-150 sealed connector and may be daisy-chained to accommodate extra modules and panels.

The power module has eight inputs and eight outputs, connected through a 20 pin Molex-150 sealed connector. The outputs are 12 V power rated at 15 amps each and include over current and automatic short circuit fault shutdown protection. The digital inputs monitor external conditions, such as what gear the transmission is in or if the ignition switch is on, and can be programmed to respond to either ground or +12 V TRUE.

The PM1 is used in conjunction with VCMS2 Switch or GM1 Module(s) in different configurations of either GM1 or PM1 MOD1 through MOD6 where up to 6 Modules are needed in a system. In these cases the application program is in the main Switch Module.

The PM1-CTRL1 is used in VCMS2 systems that have no switch module(s) (Standalone system). This may be a single PM1-CTRL1 by itself, or with up to 5 other networked PM1s (PM1-MOD2 through PM1-MOD6). In this case the application program is located in this VCMS2-PM1-CTRL1.

Modules may be ordered as VCMS2-PM1-MOD1, VCMS2-PM1-MOD2, VCMS2-PM1-MOD3, through MOD6 or as a VCMS2-PM1-CTRL1.

Key Features

- Small Size, L-bracket mounting
- Eight 12 Volt 15 Amp Power Outputs (60A max per module)
- Eight Digital Inputs
- Modular/Expandable Design
- Remote Operation
- Programmable Control Logic Functions

Related Products

- VCMS2-SM-4 thru SM-12 Switch Modules
- VCMS2-GM1 and CNTRL-1 Ground Out Modules

Mechanical Drawing

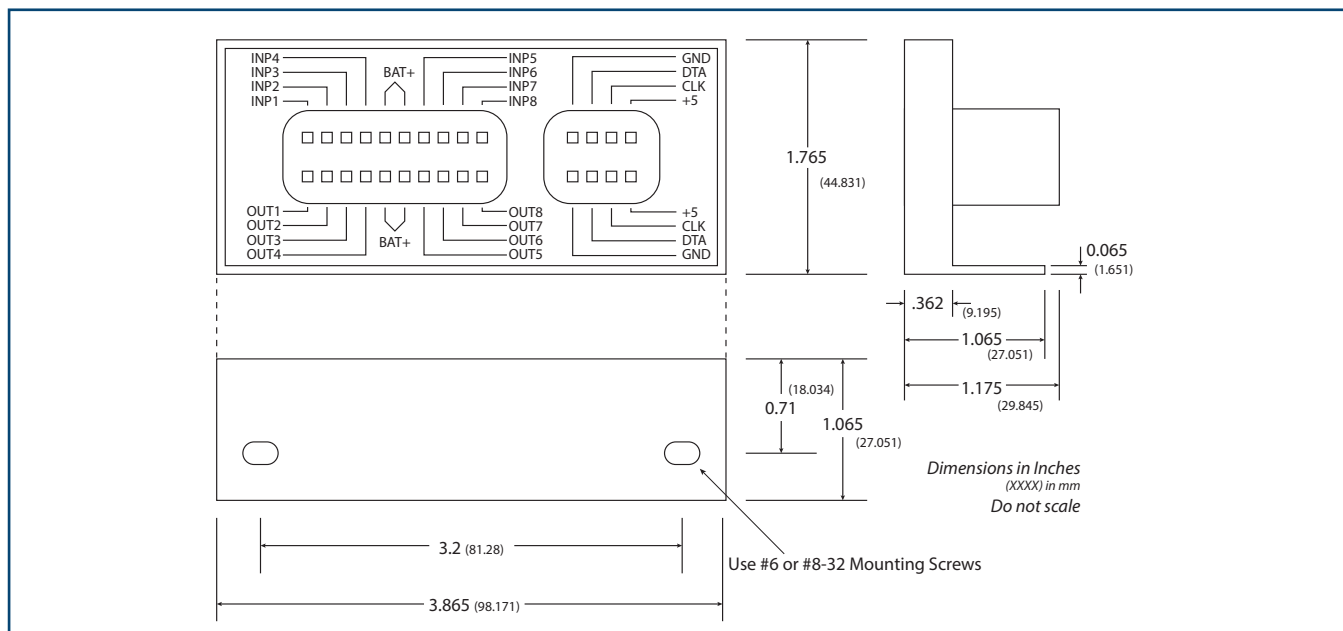

VCMS2-PM1

VCMS2-PM1-CTRL1

8 Input/ 8 Output Power Module
With Molex Connectors

Specifications

Dimensions:	Mounting Surface: 1.065 inches by 3.865 inches. 1.765 inches tall.
Case Material:	Anodized aluminum
Mounting:	Two #6-32 or #8-32 Mounting Screws through L bracket to a flat surface.
Mating Connectors:	One 20 pin A key Molex-150 (part # 33472-2001): inputs, outputs and power One 8 pin A key Molex 150 (part # 33472-0806): ground and data between modules
Outputs:	Eight high-side drivers rated for +12 volts @ 15 amps; max 60 amps per module
Inputs:	Eight programmable to pull up for ground true actuation or to pull down for +12 volt true actuation
Orderable Configurations:	VCMS2-PM1-CTRL1 (for Standalone systems (application)), VCMS2-PM1-MOD1, VCMS2-PM1-MOD2, VCMS2-PM1-MOD3, VCMS2-PM1-MOD4, VCMS2-PM1-MOD5, or VCMS2-PM1-MOD6.
Related Products:	VCMS2-SM4, VCMS2-SM6, VCMS2-SM8, VCMS2-SM10, VCMS2-SM12 switch modules, and VCMS2-GM1-CTRL1, VCMS2-GM1-MOD1, VCMS2-GM1-MOD2, VCMS2-GM1-MOD3, VCMS2-GM1-MOD4, VCMS2-GM1-MOD5, and VCMS2-GM1-MOD6,

System Diagram

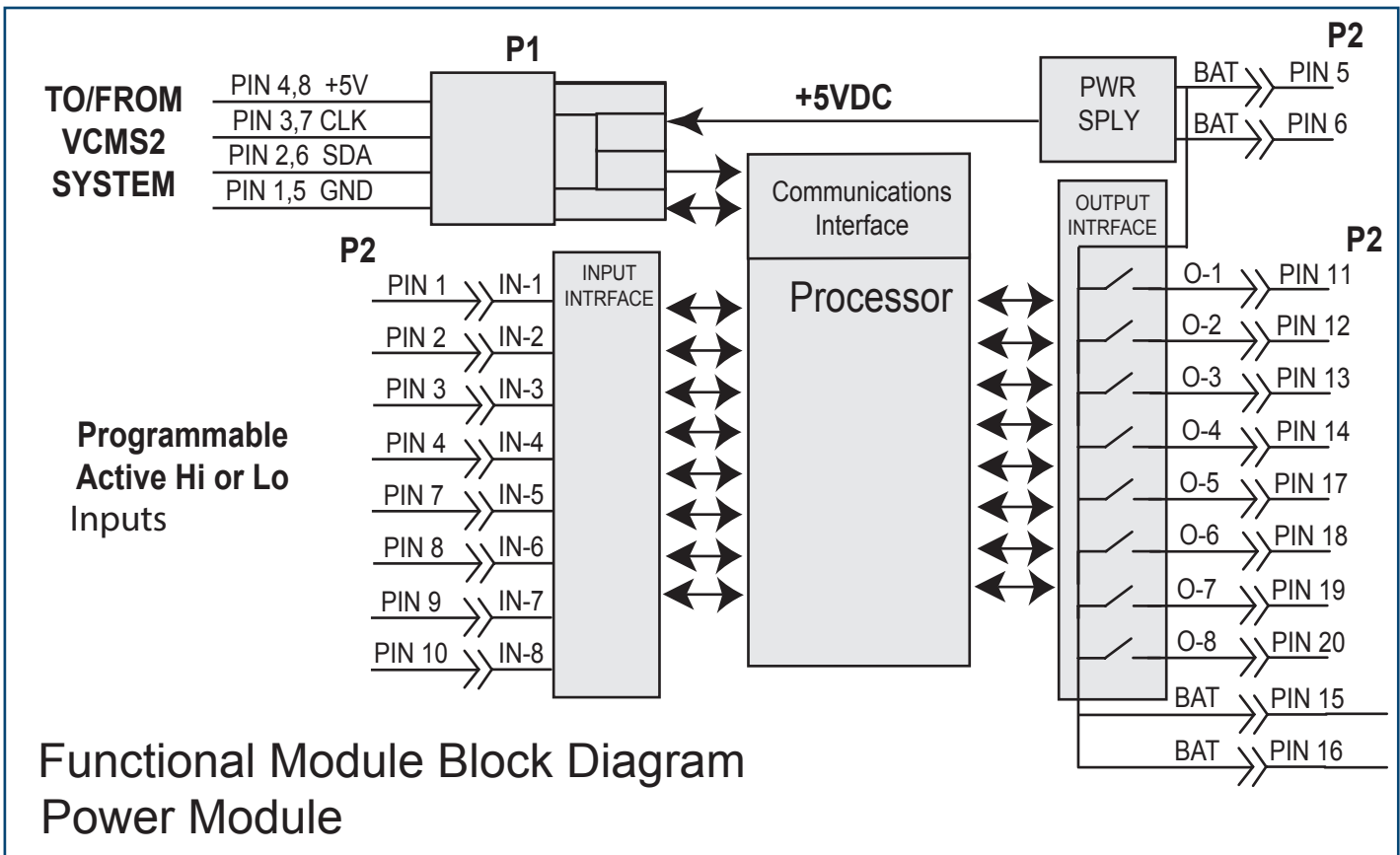

Technical Description



The Model VCMS2-SM4 Switch Module is a component of the InPower's second generation Vehicle Control Module System (VCMS2), a modular, programmable switch panel system used for controlling 12 volt auxiliary devices on vehicles. The system can be configured for a wide range of applications controlling devices such as lights, beacons, fans, compressors, and other 12 Vdc devices.

The switch module easily networks with switch modules and power modules through an eight pin Molex-150 connector. Switch modules may be arranged in a master / slave arrangement or independently. Any Slave modules (up to 2 Slaves) can have replicated switch functions allowing the same function to be controlled from separate module locations (2 or 3 different switches - Mirrored).

All power modules and switch panels connect via an 8 pin Molex-150 sealed connector and may be daisy-chained to accommodate extra modules and panels. Switch modules mount to a panel with four 6-32 threaded studs and is intended for interior vehicle locations.

Each switch position may be programmed to be momentary, two-position latching or three-position latching. All switches are backlit and each has a status LED. Legends are available in both standard and custom formats, and are easily replaced.

Key Features

- Thin Profile
- Backlit Switches
- Custom and Standard Legends
- Modular/Expandable Design
- Switch Status Indicators
- Programmable Functions
- Easy to install cable

System Diagram

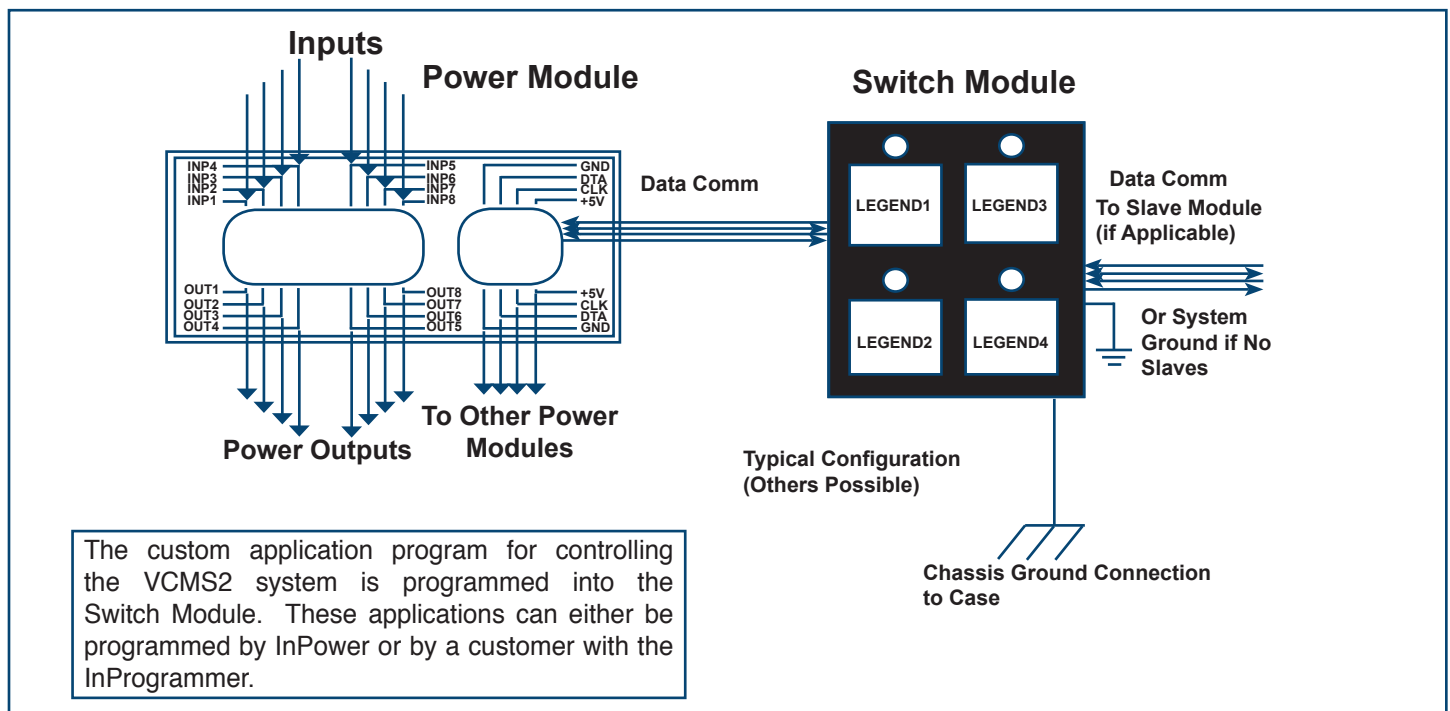

Specifications

Dimensions:	2.74 inch H x 2.33 inch W x 0.55 inch D
Case Material:	Anodized aluminum
Mounting:	Four 0.68 inch #6-32 threaded studs
Mating Connectors:	One 8 pin A key Molex 150 (part # 33472-0806): ground and data between modules
Status Indicator:	Red LED
Back Light:	Blue
Switch Cap:	Molded plastic with legend label and light diffusor
Switch Functions:	Programable as Momentary, 2-position latching (Off-On1), or 3-step (Off-On1-On2)
Switch Legends:	Custom legends available or select from InPower's standard switch legend library, document TB-59.

Mechanical Drawing

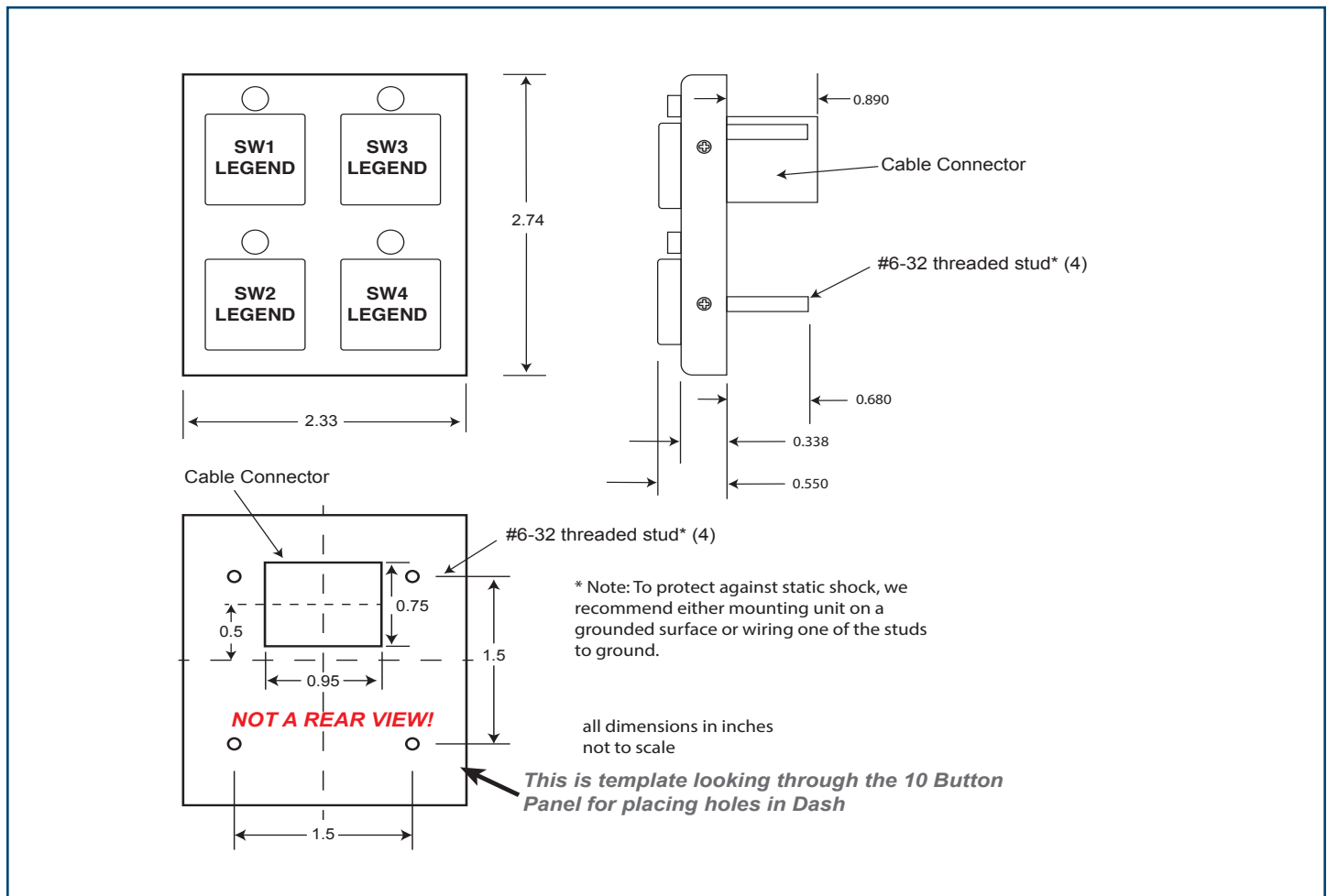



Technical Description

The Model VCMS2-SM6 Switch Module is a component of the InPower's second generation Vehicle Control Module System (VCMS2), a modular, programmable switch panel system used for controlling 12 volt auxiliary devices on vehicles. The system can be configured for a wide range of applications controlling devices such as lights, beacons, fans, compressors, and other 12 Vdc devices.

The switch module easily networks with switch modules and power modules through an eight pin Molex-150 connector. Switch modules may be arranged in a master / slave arrangement or independantly. Any Slave modules (up to 2 Slaves) can have replicated switch functions allowing the same function to be controlled from separate module locations (2 or 3 different switches - Mirrored).

All power modules and switch panels connect via an 8 pin Molex-150 sealed connector and may be daisy-chained to accomodate extra modules and panels. Switch modules mount to a panel with four 6-32 threaded studs and is intended for interior vehicle locations.

Each switch position may be programmed to be momentary, two-position latching or three-position latching. All switches are backlit and each has a status LED. Legends are available in both standard and custom formats, and are easily replaced.

Key Features

- Thin Profile
- Backlit Switches
- Custom and Standard Legends
- Modular/Expandable Design
- Switch Status Indicators
- Programmable Functions
- Easy to install cable

System Diagram

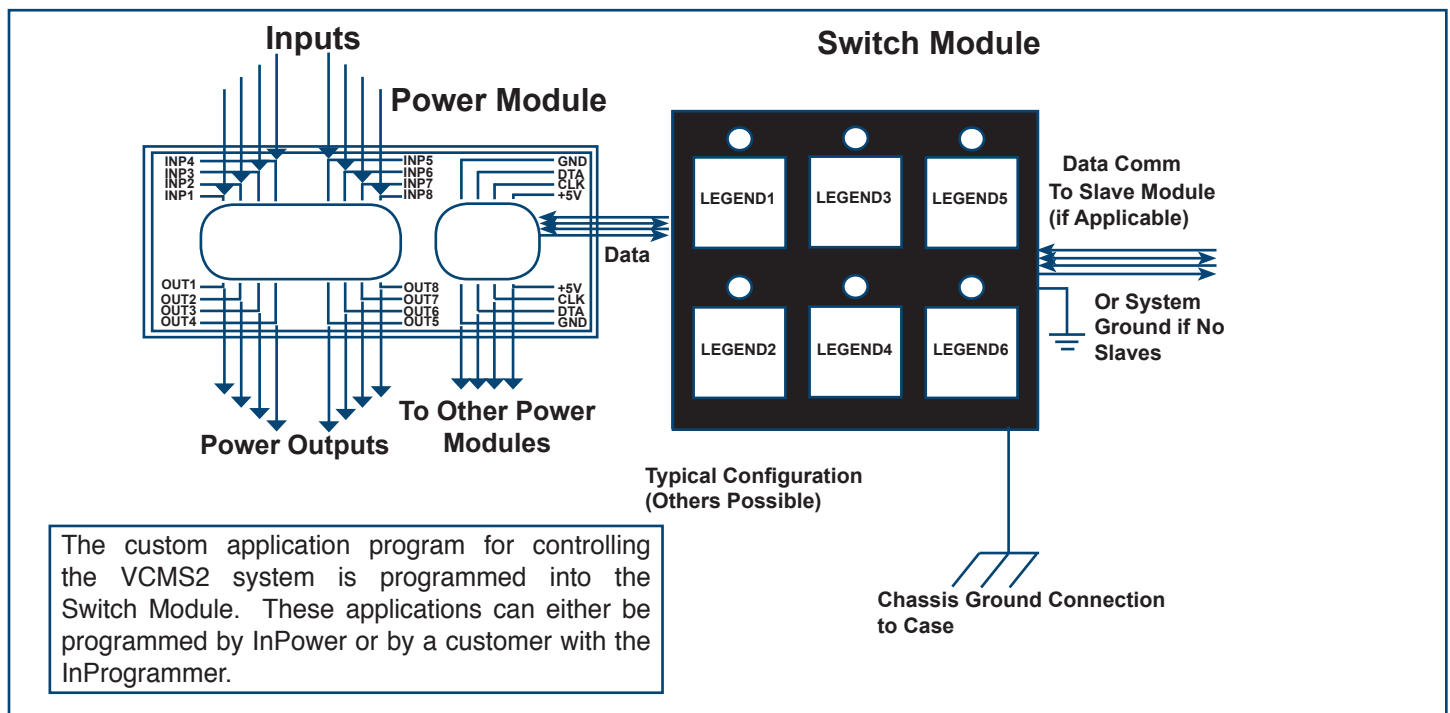

Specifications

Dimensions:	2.74 inch H x 3.33 inch W x 0.55 inch D
Case Material:	Anodized aluminum
Mounting:	Four 0.68 inch #6-32 threaded studs
Mating Connectors:	One 8 pin A key Molex 150 (part # 33472-0806): ground and data between modules
Status Indicator:	Red LED
Back Light:	Blue
Switch Cap:	Molded plastic with legend label and light diffusor
Switch Functions:	Programable as Momentary, 2-position latching (Off-On1), or 3-step (Off-On1-On2)
Switch Legends:	Custom legends available or select from InPower's standard switch legend library, document TB-59.

Mechanical Drawing

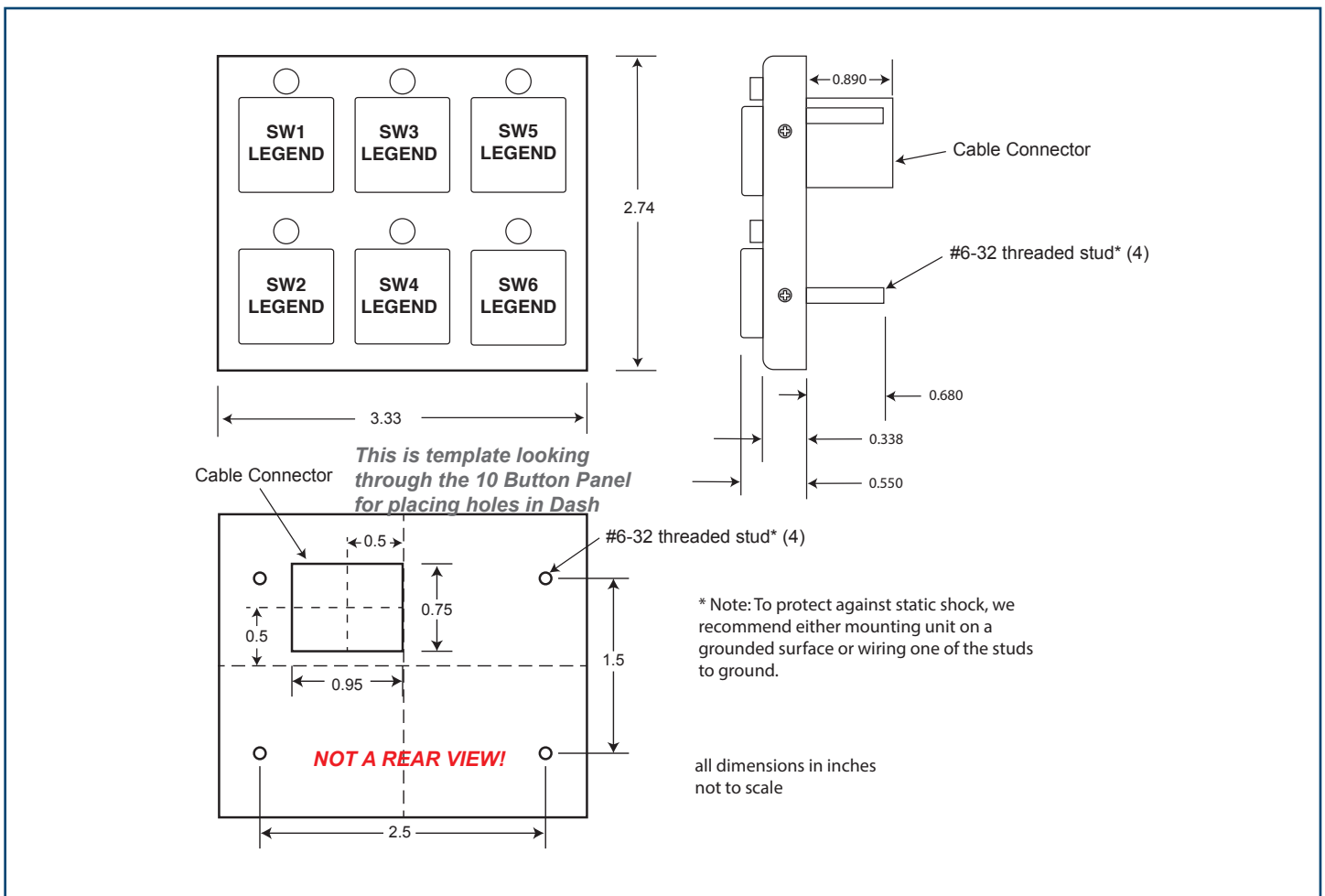

VCMS2-SM8

8 Button Switch Module with Molex Connectorization

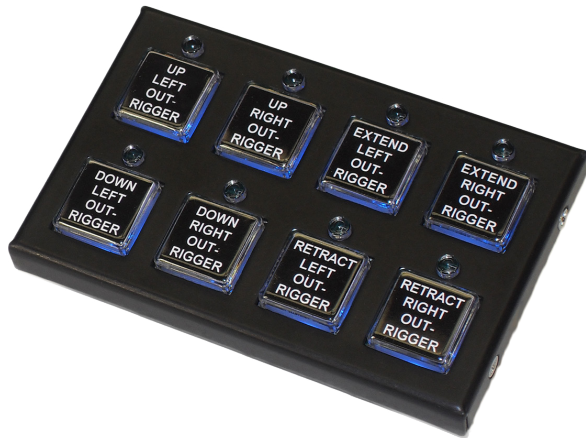

Technical Description

The Model VCMS2-SM8 Switch Module is a component of the InPower's second generation Vehicle Control Module System (VCMS2), a modular, programmable switch panel system used for controlling 12 volt auxiliary devices on vehicles. The system can be configured for a wide range of applications controlling devices such as lights, beacons, fans, compressors, and other 12 Vdc devices.

The switch module easily networks with switch modules and power modules through an eight pin Molex-150 connector. Switch modules may be arranged in a master / slave arrangement or independantly. Any Slave modules (up to 2 Slaves) can have replicated switch functions allowing the same function to be controlled from separate module locations (2 or 3 different switches - Mirrored).

All power modules and switch panels connect via an 8 pin Molex-150 sealed connector and may be daisy-chained to accomodate extra modules and panels. Switch modules mount to a panel with four 6-32 threaded studs and is intended for interior vehicle locations.

Each switch position may be programmed to be momentary, two-position latching or three-position latching. All switches are backlit and each has a status LED. Legends are available in both standard and custom formats, and are easily replaced.

Key Features

- Thin Profile
- Backlit Switches
- Custom and Standard Legends
- Modular/Expandable Design
- Switch Status Indicators
- Programmable Functions
- Easy to install cable

System Diagram

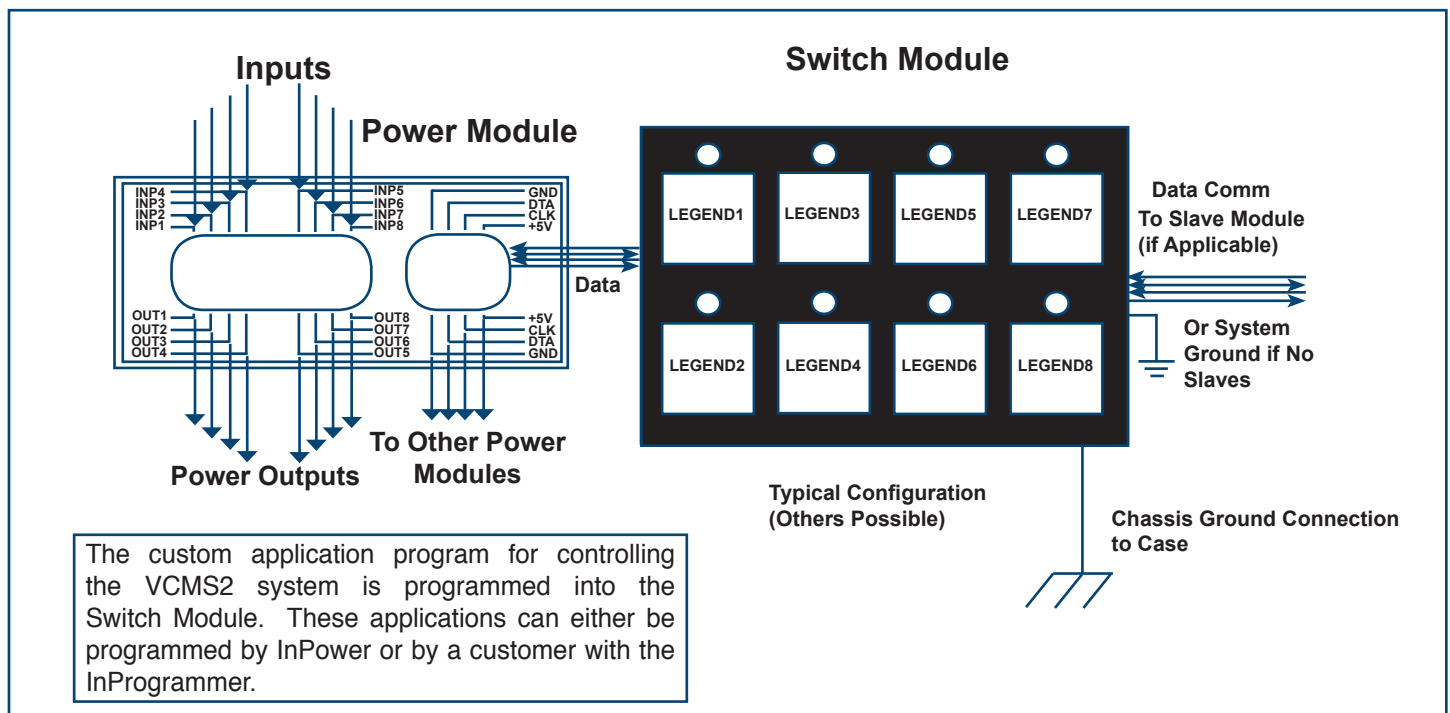

Specifications

Dimensions:	2.74 inch H x 4.33 inch W x 0.55 inch D
Case Material:	Anodized aluminum
Mounting:	Four 0.68 inch #6-32 threaded studs
Mating Connectors:	One 8 pin A key Molex 150 (part # 33472-0806): ground and data between modules
Status Indicator:	Red LED
Back Light:	Blue
Switch Cap:	Molded plastic with legend label and light diffusor
Switch Functions:	Programable as Momentary, 2-position latching (Off-On1), or 3-step (Off-On1-On2)
Switch Legends:	Custom legends available or select from InPower's standard switch legend library, document TB-59.

Mechanical Drawing

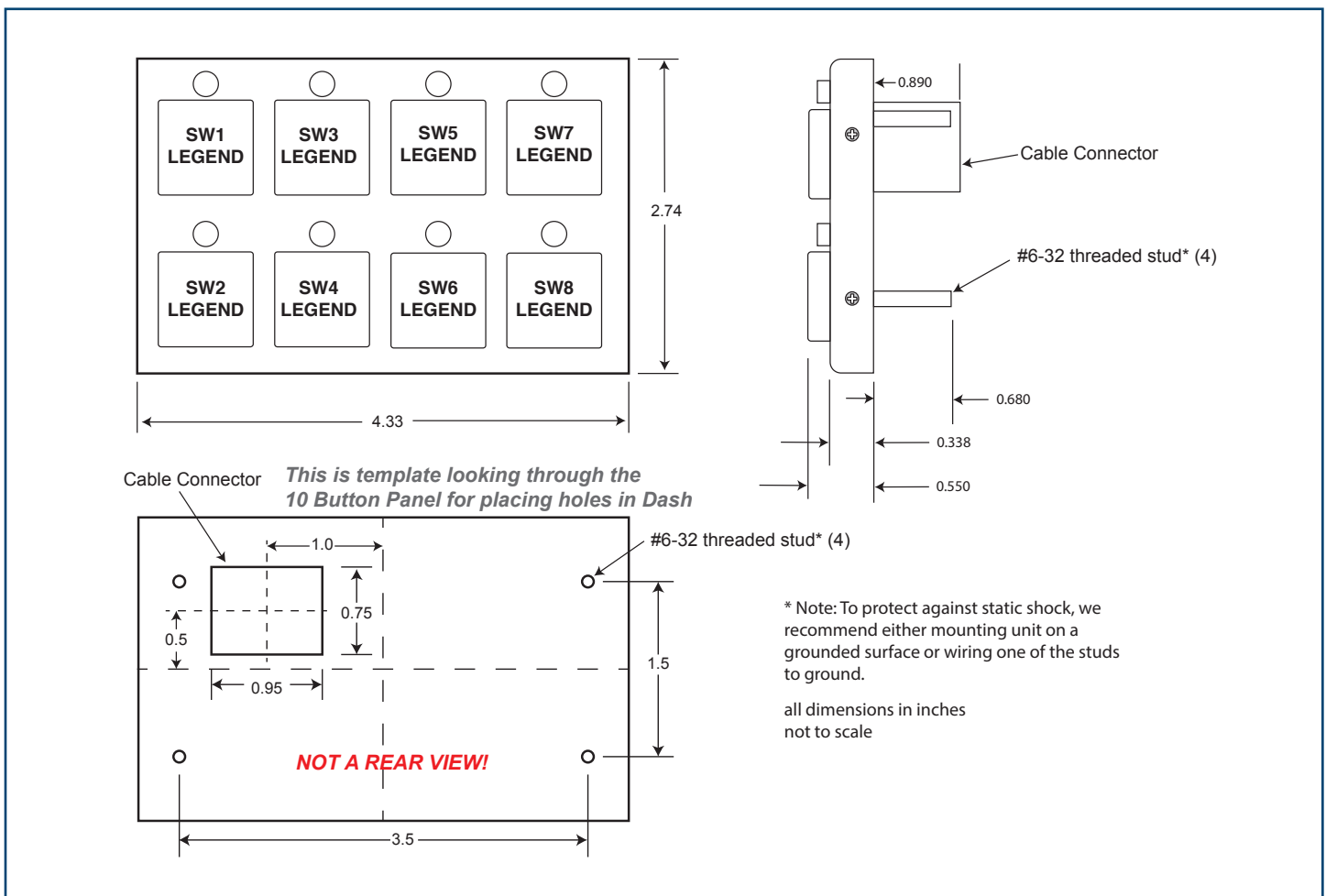

VCMS2-SM10

10 Button Switch Module with Molex Connectorization



Technical Description

The Model VCMS2-SM10 Switch Module is a component of the InPower's second generation Vehicle Control Module System (VCMS2), a modular, programmable switch panel system used for controlling 12 volt auxiliary devices on vehicles. The system can be configured for a wide range of applications controlling devices such as lights, beacons, fans, compressors, and other 12 Vdc devices.

The switch module easily networks with switch modules and power modules through an eight pin Molex-150 connector. Switch modules may be arranged in a master / slave arrangement or independantly. Any Slave modules (up to 2 Slaves) can have replicated switch functions allowing the same function to be controlled from separate module locations (2 or 3 different switches - Mirrored).

All power modules and switch panels connect via an 8 pin Molex-150 sealed connector and may be daisy-chained to accomodate extra modules and panels. Switch modules mount to a panel with four 6-32 threaded studs and is intended for interior vehicle locations.

Each switch position may be programmed to be momentary, two-position latching or three-position latching. All switches are backlit and each has a status LED. Legends are available in both standard and custom formats, and are easily replaced.

Key Features

- Thin Profile
- Backlit Switches
- Custom and Standard Legends
- Modular/Expandable Design
- Switch Status Indicators
- Programmable Functions
- Easy to install cable

System Diagram

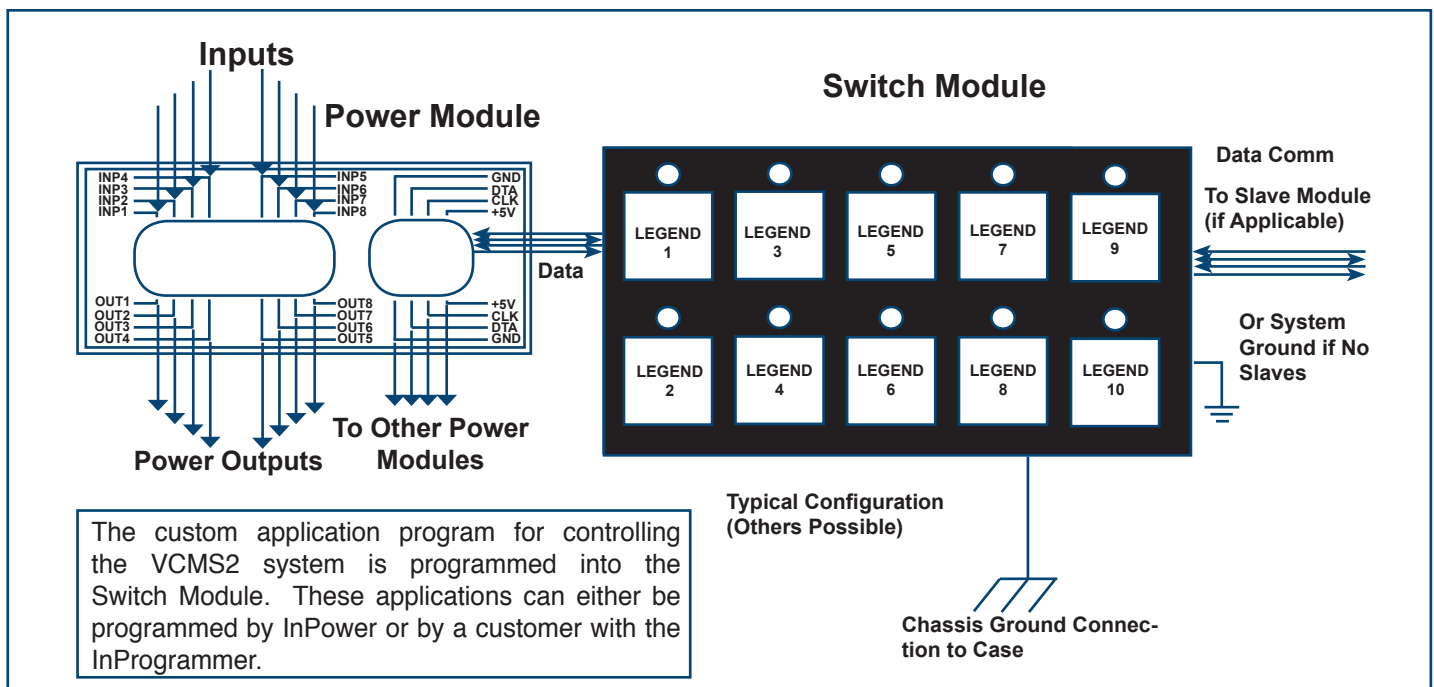

Specifications

Dimensions:	2.74 inch H x 5.33 inch W x 0.55 inch D
Case Material:	Anodized aluminum
Mounting:	Four 0.68 inch #6-32 threaded studs
Mating Connectors:	One 8 pin A key Molex 150 (part # 33472-0806): ground and data between modules
Status Indicator:	Red LED
Back Light:	Blue
Switch Cap:	Molded plastic with legend label and light diffusor
Switch Functions:	Programable as Momentary, 2-position latching (Off-On1), or 3-step (Off-On1-On2)
Switch Legends:	Custom legends available or select from InPower's standard switch legend library, document TB-59.

Mechanical Drawing

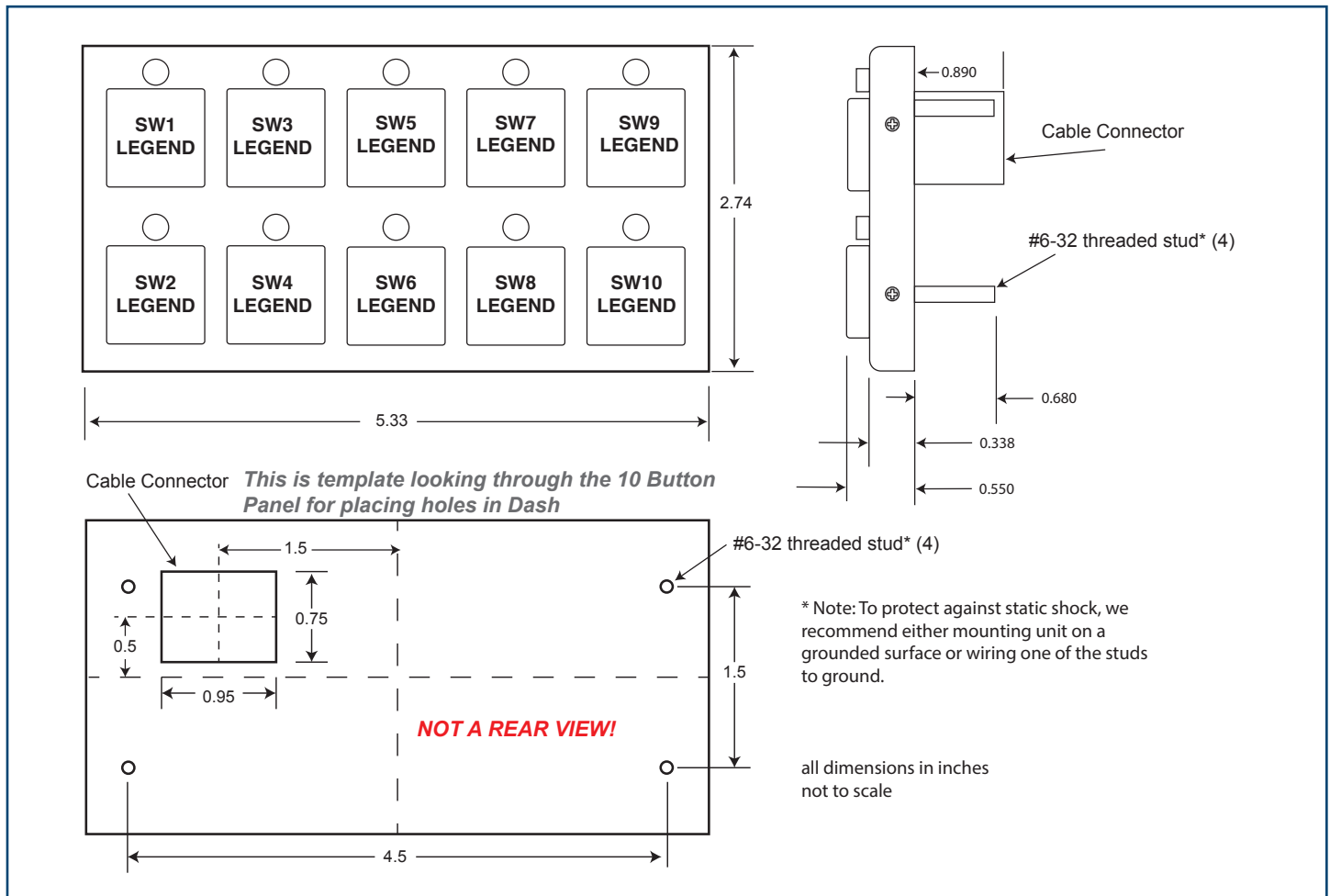

VCMS2-SM12

12 Button Switch Module with Molex Connectorization



Technical Description

The Model VCMS2-SM12 Switch Module is a component of the InPower's second generation Vehicle Control Module System (VCMS2), a modular, programmable switch panel system used for controlling 12 volt auxiliary devices on vehicles. The system can be configured for a wide range of applications controlling devices such as lights, beacons, fans, compressors, and other 12 Vdc devices.

The switch module easily networks with switch modules and power modules through an eight pin Molex-150 connector. Switch modules may be arranged in a master / slave arrangement or independantly. Any Slave modules (up to 2 Slaves) can have replicated switch functions allowing the same function to be controlled from separate module locations (2 or 3 different switches - Mirrored).

All power modules and switch panels connect via an 8 pin Molex-150 sealed connector and may be daisy-chained to accomodate extra modules and panels. Switch modules mount to a panel with four 6-32 threaded studs and is intended for interior vehicle locations.

Each switch position may be programmed to be momentary, two-position latching or three-position latching. All switches are backlit and each has a status LED. Legends are available in both standard and custom formats, and are easily replaced.

Key Features

- Thin Profile
- Backlit Switches
- Custom and Standard Legends
- Modular/Expandable Design
- Switch Status Indicators
- Programmable Functions
- Easy to install cable

System Diagram

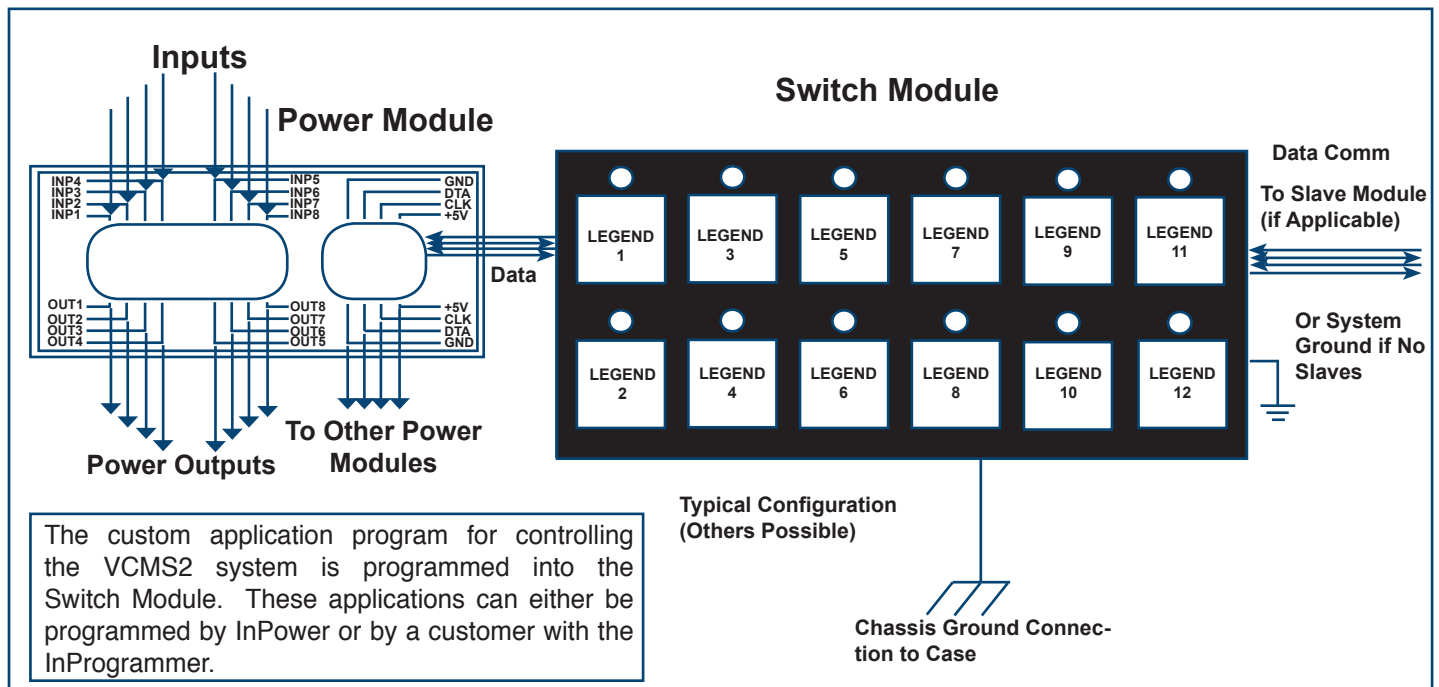

Specifications

Dimensions:	2.74 inch H x 6.33 inch W x 0.55 inch D
Case Material:	Anodized aluminum
Mounting:	Four 0.68 inch #6-32 threaded studs
Mating Connectors:	One 8 pin A key Molex 150 (part # 33472-0806): ground and data between modules
Status Indicator:	Red LED
Back Light:	Blue
Switch Cap:	Molded plastic with legend label and light diffusor
Switch Functions:	Programable as Momentary, 2-position latching (Off-On1), or 3-step (Off-On1-On2)
Switch Legends:	Custom legends available or select from InPower's standard switch legend library, document TB-59.

Mechanical Drawing

