



TITAN

SERIES

Hermetically Sealed Heads: Ultrasonically welding the lens to the base and sealing the wire exit hole, allows for a waterproof and dust proof seal with an IP69 rating.

Field Replaceable Heads: The light modules are field replaceable with the spring clip fastening system and connectorized wire harness.

Waterproof Connectors: The high quality TE Deutsch connector provides superior waterproofing and a secure connection for all the lighthead and main power lines.

Cargo Lighting & AutoDim: Fleet Plus models feature an on board photosensor which will automatically dim the lighthead under low ambient light levels. The Fleet Plus models also include 2 white cargo lights to provide some illumination to the area directly behind the traffic director.

Unparalleled Light Output: The lighthead produce a blistering 4750cd warning signal per module, while consuming very little power. Furthermore, the projection optics allow the light to be seen well in advance of the vehicle.

SWS

NEW!

57000 SERIES TRAFFIC ARROWS FLEET

TITAN
S E R I E S

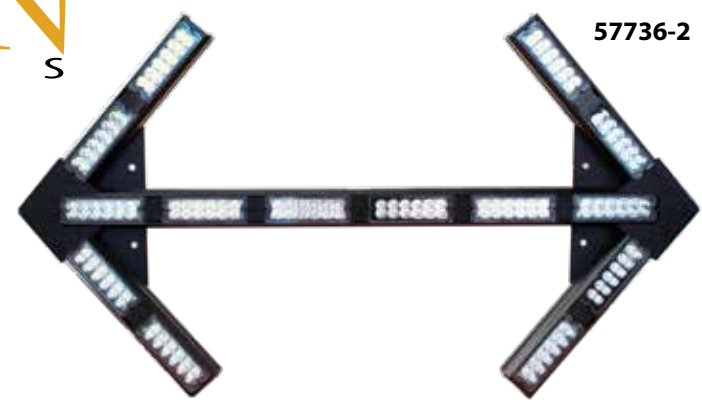

Control Box & Cable Options (sold separately)



77501



Main Power Cable
To be used with 77501
20' - 77260
30' - 77261
40' - 77262
50' - 77263



77504 Outdoor Rated Switch Box



Main Power Cable
To be used with 77504
10' - 77270
20' - 77271
30' - 77272
40' - 77273

Features

- The hermetically sealed light-head will not be affected by outside factors such as temperature, humidity & condensation
- NO DOWN TIME – heads are field replaceable in less than one minute!
- SWS pressure clip system ensure that no special tools are ever required
- A choice of control platforms – cab-mounted slim-line control box or NEW outdoor rated switch box
- All electrical connections are made using the industry known and trusted DTM series connections from TE
- Adapter kit available for use on existing wire installations (77280)
- Stop-Turn lighting kits available (96050)
- **5 Year Warranty (Control box 1 Year Warranty)**



NEW!

57000 SERIES TRAFFIC ARROWS FLEET

TITAN
S E R I E S

Dimensions

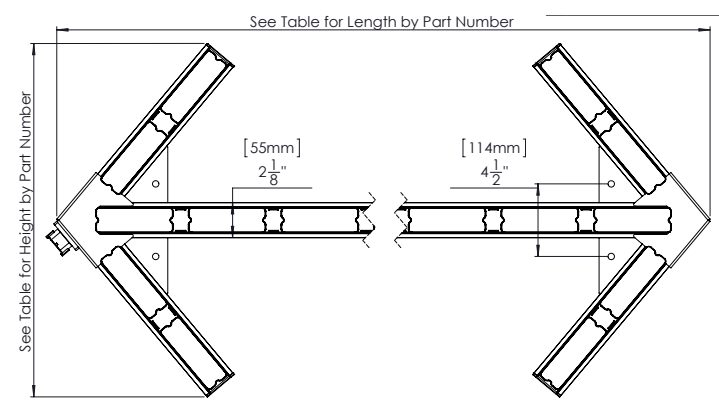

Available Colors



* All part numbers listed are amber color. Contact factory for custom requests

Part #	Vdc	Amps	# of Modules in Shaft	# of Modules per Arm	Flash Patterns	Length	Height
57724-1	12	1.8A	4	1	7	27"	12.5"
57730-1	12	1.8A	5	1	7	32.75"	12.5"
57730-2	12	2.4A	5	2	7	32.75"	22"
✓ 57736-1	12	2.1A	6	1	7	38.5"	12.5"
✓ 57736-2	12	2.7A	6	2	7	38.5"	22"
57736-3	12	3.3A	6	3	7	38.5"	30.5"
✓ 57742-1	12	2.4A	7	1	7	44.25"	12.5"
✓ 57742-2	12	3.0A	7	2	7	44.25"	22"
57742-3	12	3.6A	7	3	7	44.25"	30.5"
✓ 57748-1	12	2.7A	8	1	7	50"	12.5"
✓ 57748-2	12	3.3A	8	2	7	50"	22"
57748-3	12	3.9A	8	3	7	50"	30.5"
57754-1	12	3.0A	9	1	7	55.75"	12.5"
57754-2	12	3.6A	9	2	7	55.75"	22"
57754-3	12	4.2A	9	3	7	55.75"	30.5"
57760-1	12	3.3A	10	1	7	61.5"	12.5"
57760-2	12	3.9A	10	2	7	61.5"	22"
57760-3	12	4.5A	10	3	7	61.5"	30.5"
57766-1	12	3.3A	11	1	7	67.25"	12.5"
57766-2	12	3.9A	11	2	7	67.25"	22"
57766-3	12	4.5A	11	3	7	67.25"	30.5"
57772-1	12	3.6A	12	1	7	73"	12.5"
57772-2	12	4.2A	12	2	7	73"	22"
57772-3	12	4.8A	12	3	7	73"	30.5"

✓ = Top Seller

NEW!

57000 SERIES SPLIT TRAFFIC ARROWS

FLEET
TITAN
SERIES

57824-1



(cable sold separately)

Features

- The hermetically sealed light-head will not be affected by outside factors such as temperature, humidity & condensation
- NO DOWN TIME – heads are field replaceable in less than one minute!
- SWS pressure clip system ensure that no special tools are ever required
- A choice of control platforms – cab-mounted slim-line control box or NEW outdoor rated switch box
- All electrical connections are made using the industry known, and trusted DTM series connections from TE
- Adapter kit available for use on existing wire installations (77280, power cable only)
- **5 Year Warranty (Control box 1 Year Warranty)**

Control Box & Cable Options (sold separately)



77501



Main Power Cable
To be used with 77501
20' - 77260
30' - 77261
40' - 77262
50' - 77263



77504 Outdoor Rated Switch Box



Main Power Cable & Extension Cable
To be used with 77504
& between halves
10' - 77270
20' - 77271
30' - 77272
40' - 77273

Available Colors



* All part numbers listed are amber color. Contact factory for custom requests

Available Models							
Part #	Vdc	Amps	# Modules per half	Number of Modules	Flash Patterns	Length	Height
57818-1	12	2.1A	3	1	7	20"	12.5"
57818-2	12	2.7A	3	2	7	20"	22"
57818-3	12	3.3A	3	3	7	20"	30.5"
57824-1	12	2.7A	4	1	7	26"	12.5"
57824-2	12	3.3A	4	2	7	26"	22"
57824-3	12	3.9A	4	3	7	26"	30.5"
57830-1	12	3.3A	5	1	7	31.75"	12.5"
57830-2	12	3.9A	5	2	7	31.75"	22"
57830-3	12	4.5A	5	3	7	31.75"	30.5"
57836-1	12	3.6A	6	1	7	37.5"	12.5"
57836-2	12	4.2A	6	2	7	37.5"	22"
57836-3	12	4.8A	6	3	7	37.5"	30.5"

NEW!

57000 SERIES TRAFFIC DIRECTORS

FLEET
TITAN
SERIES

57524



(cable sold separately)

Features

- The hermetically sealed light-head will not be affected by outside factors such as temperature, humidity & condensation
- NO DOWN TIME – heads are field replaceable in less than one minute!
- SWS pressure clip system ensure that no special tools are ever required
- A choice of control platforms – cab-mounted slim-line control box or NEW outdoor rated switch box
- All electrical connections are made using the industry known, and trusted DTM series connections from TE
- 3 T-slots for unlimited mounting options (1/4" - 20 hardware included)
- Adapter kit available for use on existing wire installations (77280, power cable only)
- **5 Year Warranty (Control box 1 Year Warranty)**

Control Box & Cable Options (sold separately)



77501



77504 Outdoor Rated Switch Box

Main Power Cable
To be used with 77501
20' - 77260
30' - 77261
40' - 77262
50' - 77263



Main Power Cable & Extension Cable
To be used with 77504
& between halves
10' - 77270
20' - 77271
30' - 77272
40' - 77273



Available Colors



* All part numbers listed are amber color. Contact factory for custom requests

Available Models					
Part #	Vdc	Amps	# Modules per half	Flash Patterns	Length
57524	12	2.4A	4	5	23.625"
57530	12	3.0A	5	5	29.375"
57536	12	3.6A	6	5	35.125"
57542	12	4.2A	7	5	40.875"
57548	12	4.8A	8	5	46.625"

Dimensions

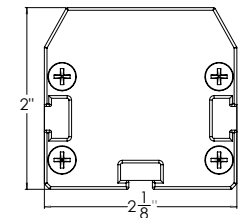

TRAFFIC ARROWS In cab control box

- **BatteryCheck™**
- **Manual Dim**
- **10 Amp Auxiliary**

(definitions refer to page 2)

Features

- 12-24 Vdc operating range
- Double confirmation of button activation with a visual indicator LED and an internal audible buzzer
- BatteryCheck™ feature utilizes front mounted pattern matrix LEDs, to indicate the vehicles battery level
- Rugged compact design has a front tactile panel with indicator LEDs, an aluminum mounting bracket for above or below universal mounting options, and protected internal circuitry
- Included 10amp. auxiliary channel is independently controllable
- Has both a manual dimming option and cargo light control (for capable products)
- Quick disconnect wiring harness connection for fast installation
- **1 Year Warranty**



Dimensions

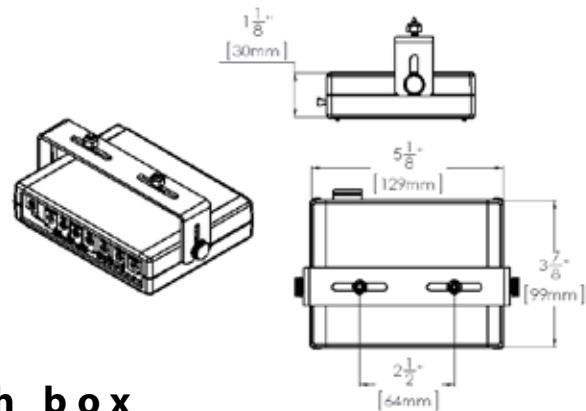

Outdoor rated switch box

Features

- For use with Titan FLEET traffic arrows and traffic directors only.
- 12Vdc operating voltage.
- IP66 rated control box and 5-position switch, for externally mounting the control system
- Industry standard 4 patterns; Left, Right, Bar/Warning, Center Out
- Supplied with a 12" min. power leads, and a connector harness for quick installation to the traffic directing device.
- Includes stainless steel mounting hardware
- **1 Year Warranty**



Dimensions

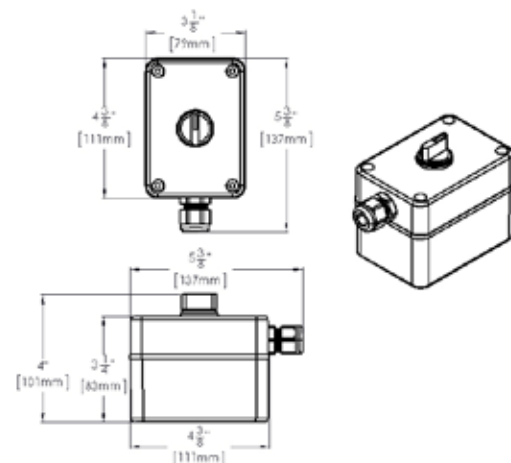

TRAFFIC ARROWS 54000 Series

- **5 Year Warranty** 
- **AutoDim™** 
- **1 wire communication**

(definitions refer to page 2)



Included with 54000



Included with 54002

Main Power Cable
To be used with 77501 (sold separately)
20' - 77250
30' - 77251
40' - 77252
50' - 77253



Main Power Cable
To be used with 77504 (sold separately)
10' - 77270
20' - 77271
30' - 77272
40' - 77273



Dimensions

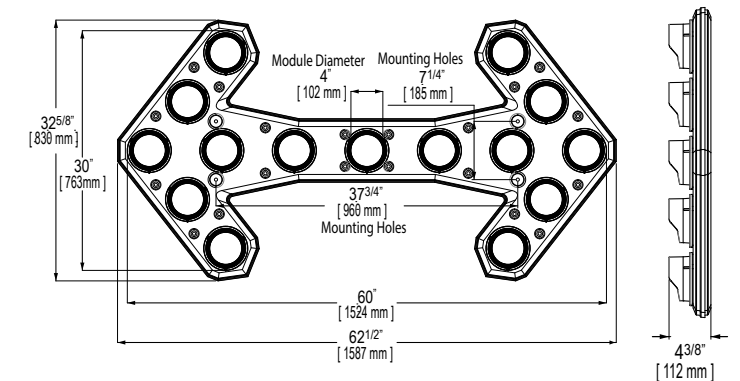

Available Models

Part #	Vdc	Mounting	Module Color	Amps	Lumens	# Patterns	Weight	Control Box / Switch
54000	12	PM	Amber	5.25	4680 max	7	25lbs	77501
54002	12	PM	Amber	5.25	4680 max	4	25lbs	77504